

This is a general specification leaflet ; for specific applications not covered herein, contact Suntec.

The SUNTEC J oil pump is for medium capacity oil burners from 400 to 3000kW. It incorporates a pressure regulating valve and is available with or without cut-off function.

### COMPATIBILITY

- Light and medium oil, HVO, B100 (biofuel blend with the addition up to 100% FAME, as defined in DIN SPEC 51603-6 or EN 14214). For kerosene applications, contact Suntec.
- One or two-pipe system.
- Normally associated with in-line solenoid valve.

### PUMP OPERATING PRINCIPLE

The gear set draws oil from the tank through the built-in filter and transfers it to the valve that regulates the oil pressure to the nozzle line. All oil that does not go through the nozzle line will be dumped through the valve back to the return line in two pipe installation or, if it is a one-pipe installation, back to the suction port in the gear-set. In that case, the by-pass plug must be removed from the return port and the return port sealed by steel plug and washer.

Models 1000 & 1001, the valve also has a cut-off function as follows :

- During starting period when the gear-set speed is increasing, all the oil passes through a special flat on the piston, back to the return. Once the speed reaches a certain value and the flow can no longer pass through this flat, then the pressure increases rapidly overcoming the valve spring force and opens the valve.
- During the stop sequence, the gear-set speed slows down and the valve closes when the gear-set capacity is lower than the flat flow.

The cut-on and cut-off speeds depend on the gear-set size and set pressure.

Models 1002 & 1003 have no cut-off function. Cut-off must be provided by an external solenoid valve.

### Bleed :

Bleeding in two pipe operation is automatic, but it may be accelerated by loosening the plug in a pressure gauge port.

In one pipe operation, a pressure port must be opened to bleed the system.

# J

## PUMP IDENTIFICATION

(Not all model combinations are available. Consult your Suntec representative)

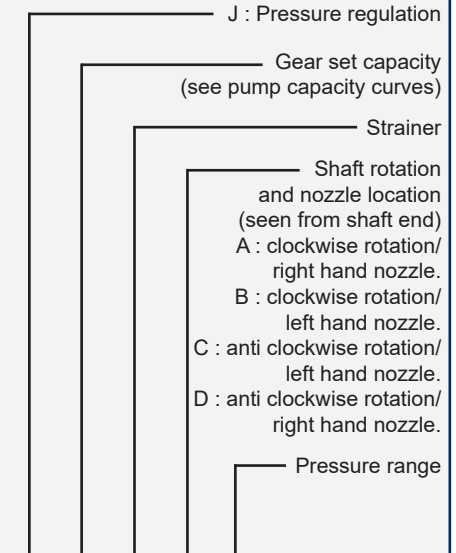

**J 6 P A C 1001 8 P**

- 1000 : conical connection threads cut-off function
- 1001 : cylindrical connection threads cut-off function
- 1002 : cylindrical connection threads by-pass nozzle, no cut-off function
- 1003 : conical connection threads by-pass nozzle, no cut-off function

Revision number

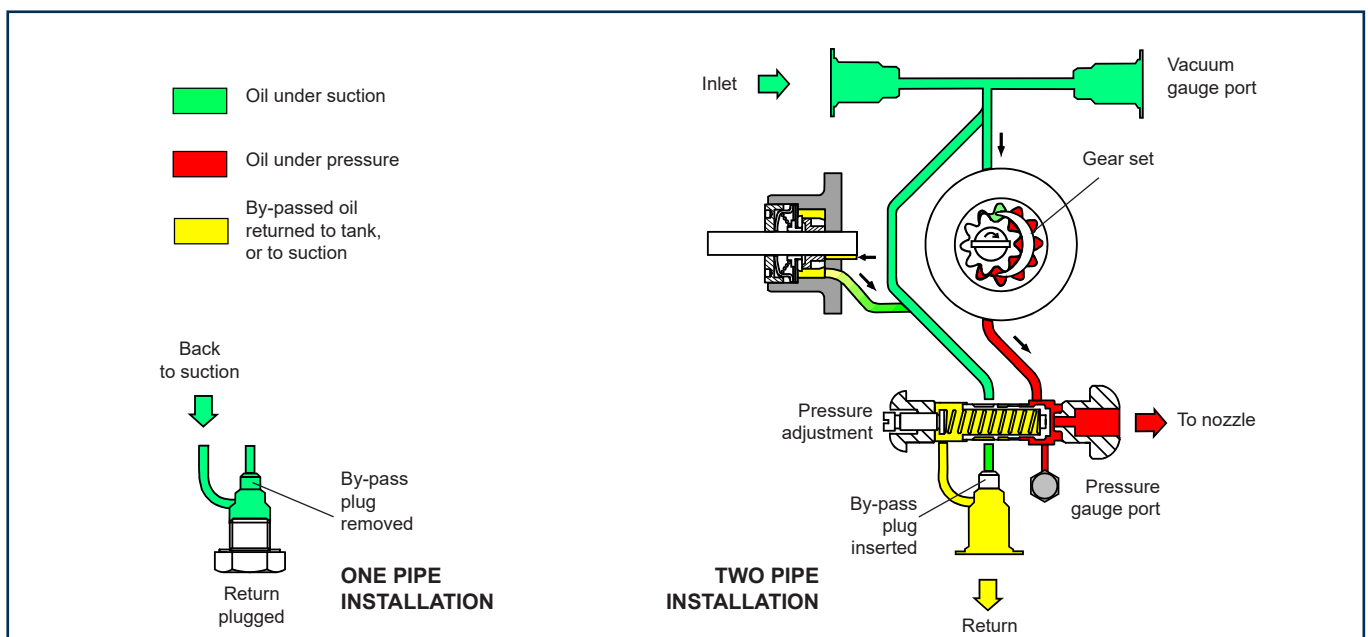

Installation

- P : by-pass plug installed in return port for two-pipe operation
- M : without by-pass plug; return plugged for one-pipe operation



## TECHNICAL DATA

### General

Mounting	Flange mounting according to EN 225.	
	Models 1000/1003	Models 1001/1002
Connection threads	Conical	Cylindrical (according to ISO 228/1)
Inlet and return	1/4 NPTF	G 1/2
Nozzle outlet	1/8 NPTF	G 1/4
Pressure gauge port	1/8 NPSF	G 1/8
Vacuum gauge port	1/4 NPTF	G 1/2
Valve function	Pressure regulating and cut-off (except for 1002 and 1003 models).	
Strainer	Open area	Opening size
P :	97cm <sup>2</sup>	170µm
N :	45cm <sup>2</sup>	550µm
L :	No filter	
Shaft	Ø 11mm according to EN 225.	
By-pass plug	Inserted in return port for 2 pipe system; to be removed with a 3/16" Allen key for 1 pipe system.	
Weight	4 kg	
Certified	 	except J7 and pressure range K : UR certified

### Hydraulic data

Pressure range	Delivery pressure setting
A : 1,4 - 2,8 bars	2,8 bars
B : 7 - 14 bars	7 bars
C : 10 - 21 bars	12 bars
D : 2,8 - 5,5 bars	5,5 bars
F : 0,7 - 1,4 bars	0,7 bars
K : 14 - 30 bars	20 bars (for J1000 and J1001)
	12 bars (for J1002 and J1003)
Operating viscosity	2 - 75 mm <sup>2</sup> /s (cSt) for J4/J6 3 - 75 mm <sup>2</sup> /s (cSt) for J7 <i>(For kerosene applications, contact SUNTEC)</i>
Oil temperature	0 - 90°C in the pump.
Inlet pressure	1,5 bars max.
Return pressure	1,5 bars max.
Suction height	0,45 bars max. vacuum to prevent air separation from oil.
Rated speed	3600 rpm max.
Torque (@ 45 rpm)	0,30 N.m

### Pump capacity

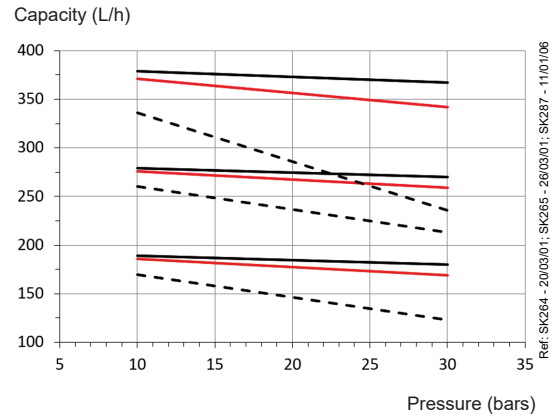

Viscosity =   
— 75 cSt  
— 20 cSt  
- - - 5 cSt - Rated speed = 2850 rpm

Data shown take into account a wear margin.  
Do not oversize the pump when selecting the gear capacity.

### Power consumption

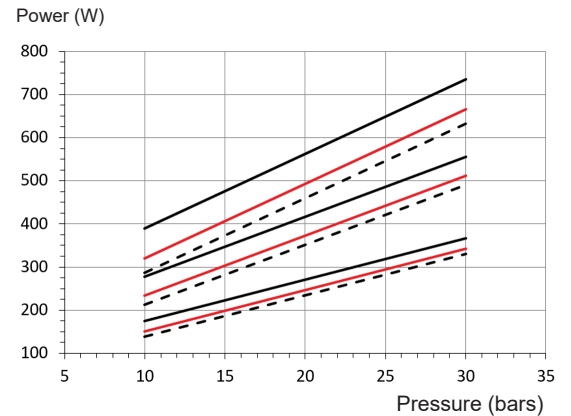

Viscosity =   
— 75 cSt  
— 20 cSt  
- - - 5 cSt - Rated speed = 2850 rpm

## PUMP DIMENSIONS (in mm)

Examples shows "C" rotation and nozzle outlet.

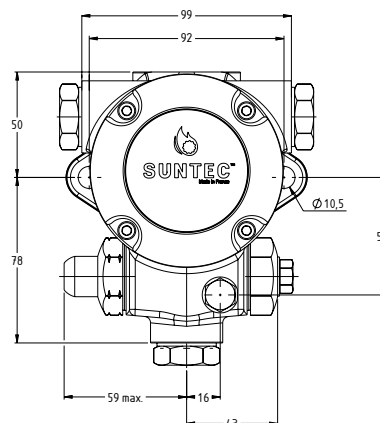
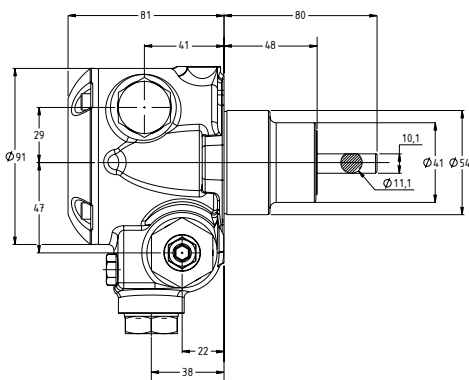

- ① Suction or vacuum gauge port
- ② Return and internal by-pass plug
- ③ Nozzle outlet
- ④ Pressure gauge port
- ⑤ Vacuum gauge port or suction
- ⑥ Pressure adjustment