

This is a general specification leaflet; for specific applications not covered herein, contact Suntec.

The SUNTEC **AP** oil pump has a built-in solenoid which provides a two-mode pressure operation.

COMPATIBILITY

- Domestic oil, HVO, B30 (biofuel blend with the addition of 30% FAME, as defined in DIN SPEC 51603-6).
- Two-pipe or one-pipe system.
- Requires a separate cut-off valve.

PUMP OPERATING PRINCIPLE

The gear-set draws oil from the tank through the built-in filter and transfers it to the pressure regulating valve.

The high pressure mode is obtained with the solenoid valve activated (ie. closed); activating this solenoid valve closes the by-pass channel to the return. Oil is then transferred to the nozzle line at the pressure given by the high pressure regulating valve.

The low pressure mode is obtained with the solenoid valve open (ie. non activated); the by-pass channel is open, the oil is supplied to the nozzle line via the by-pass hole and the low pressure adjustment is made by the screw on the solenoid tube.

It is preferable to set the high pressure given by the pump valve (with solenoid activated) before the low pressure, with solenoid non activated. Care should be taken not to overtighten the low pressure adjusting screw of the solenoid tube, as this may eliminate the low pressure range.

For two pipe installation, the by-pass plug fitted in the return port allows any oil not required at the nozzle to be dumped back to the tank. For one pipe installation, the by-pass plug must be removed and the return port plugged, oil which is not required at the nozzle is then returned back to the suction port in the gear set.

Bleed

Bleeding is assured by the by-pass hole of the nozzle plug.

For the first start up, bleeding can be accelerated by loosening the plug of a pressure port.

Note

Owing to the presence of the nozzle by-pass hole, the pump has no cut-off function; cut-off must be provided by an external solenoid valve.

PUMP IDENTIFICATION

(Not all model combinations are available.
Consult your Suntec representative)

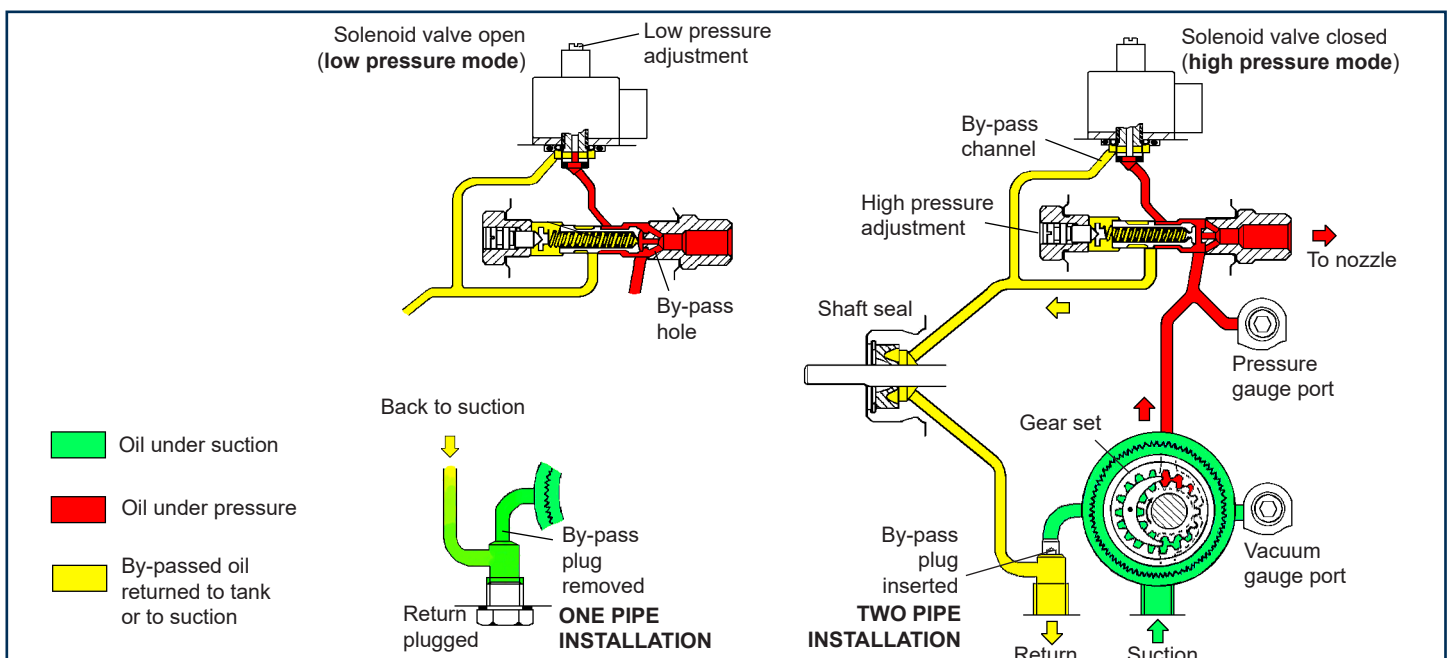
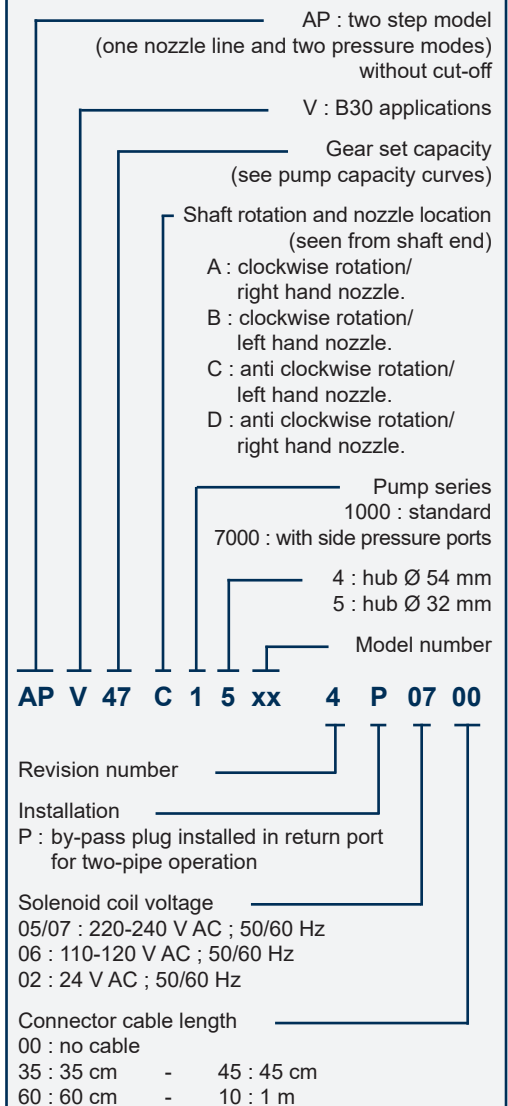

TECHNICAL DATA

General

Mounting	Flange or hub mounting according to EN 225
Connection threads	cylindrical according to ISO 228/1
Inlet and return	G 1/4 (with facilities for conical sealing on revision 6 models)
Nozzle outlet	G 1/8
Pressure gauge port	G 1/8
Vacuum gauge port	G 1/8
Valve function	Pressure regulation
Strainer	open area : 6 cm ² - opening size : 150 µm
Shaft	Ø 8 mm according to EN 225
By-pass plug	inserted in return port for two-pipe system ; to be removed from return port with a 4 mm Allen key for one pipe system.
Weight	1,1 - 1,5 kg (depending on the model)

Hydraulic Data

Gear size	Nozzle pressure range*	Delivery pressure settings
47/57	Low mode: 3 - 15 bars High mode: 10 - 28 bars	9 bars 22 bars
67	Low mode: 5 - 15 bars High mode: 10 - 28 bars	9 bars 22 bars

*Other ranges available on request, refer to the specified range of the particular fuel unit.

Operating viscosity	2-12 mm ² /s (cSt)
Oil temperature	0 - 60°C max. in the pump
Inlet pressure	2 bars max.
Return pressure	2 bars max.
Suction height	0,45 bars max. vacuum to prevent air separation from oil.
Rated speed	3600 rpm max.
Torque (@ 45 rpm)	0,10 N.m (AP 47/57) - 0,12 N.m (AP 67)

Solenoid valve characteristics

Voltage	220-240 or 110-120 or 24 V; 50/60 Hz
Consumption	9 W max.
Coil Code*	Ambient temperature
06/02/05	0 - 60 °C
07	0 - 80 °C

*Refer to "Pump identification - solenoid coil voltage".

Maximum pressure	28 bars
Protection class	IP 54 according to EN 60529, when used with SUNTEC connector cable.

Pump capacity - High mode

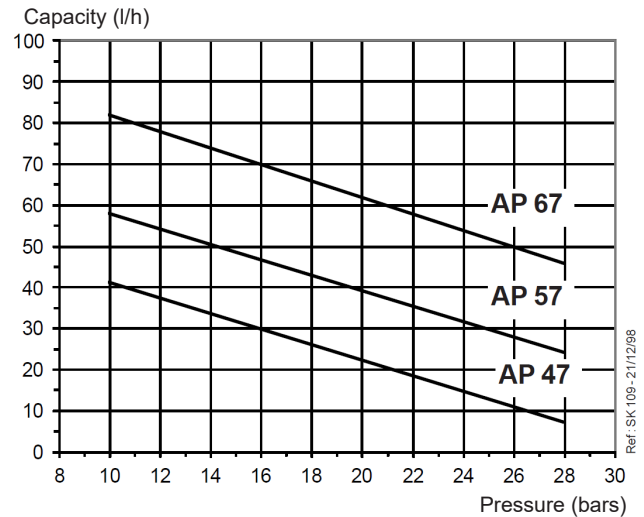

Viscosity= 5 cSt - Rated speed = 2850 rpm

Data shown take into account a wear margin.
Do not oversize the pump when selecting the gear capacity.

Power consumption

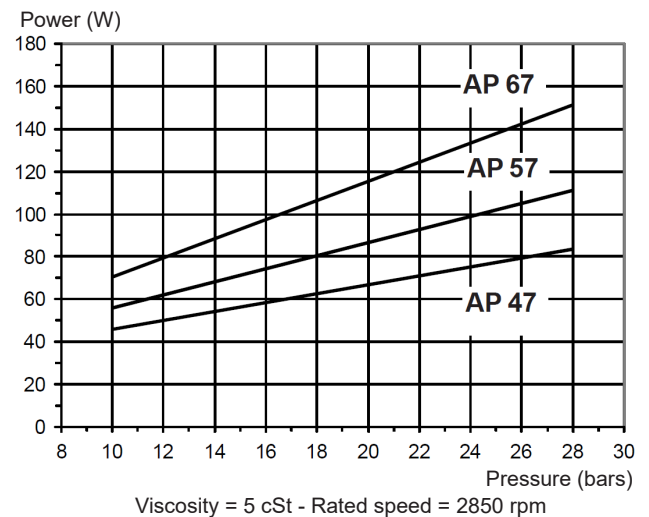

Viscosity = 5 cSt - Rated speed = 2850 rpm

DIMENSIONS

PUMP (Example shows "C" rotation and nozzle outlet)

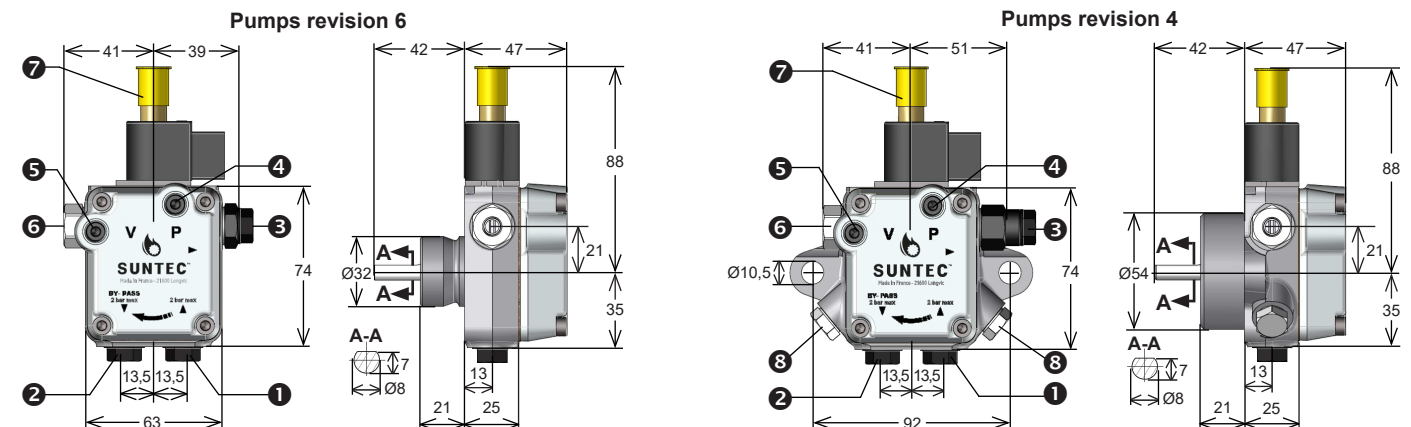

- ① Suction
- ② Return and internal by-pass plug
- ③ Nozzle outlet
- ④ Pressure gauge port
- ⑤ Vacuum gauge port
- ⑥ High pressure adjustment
- ⑦ Low pressure adjustment
- ⑧ Pressure port (only for "7000" series)

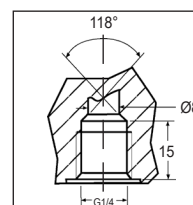

Inlet ① and Return ② with direct sealing for revision 6 models (sealing with washers can also be used)