

The SUNTEC OL oil pump incorporates a blocking solenoid valve with in-line cut-off function.

### COMPATIBILITY

- Fuel oil #2 and lighter, special "V" models for B6-B20 (blends from 6% up to 20% biodiesel, per ASTM D396) and "K" models for Kerosene.
- One or two-pipe system.

### PUMP OPERATING PRINCIPLE

The gear set draws oil from the tank through the built-in filter and transfers it to the nozzle line via the cut-off solenoid valve. A pressure regulating valve is used to by-pass all oil which is not required at the nozzle.

#### One-pipe installation

The oil which does not go through the nozzle line is returned directly to the gear inlet and the suction line flow is equal to the nozzle flow. In that case, the by-pass plug must be removed from the return port, and the return port sealed by steel plug and washer.

#### Two-pipe operation

The by-pass plug is fitted in the return port, which ensures that the oil by-passed by the regulating valve is returned to the tank and the suction line flow is equal to the gear set capacity.

#### Cut-off

The solenoid valve of the OL pump is of the "normally closed" type and is situated in the nozzle line. This design ensures extremely fast response and the switching can be selected according to the burner operating sequence and is independent of motor speed.

When the solenoid is :

- non-activated, the valve is closed and all oil pressurized by the gear set passes through the regulator to suction or the return line, depending upon pipe arrangement.
- activated, oil passes to the nozzle line at the pressure set by the pressure regulating valve.

#### Bleed

In one-pipe operation, the bleeder valve must be loosened ( or a pressure port must be opened) until the air is evacuated from the system.

Bleeding in two-pipe operation is automatic : it is assured by a bleed flat on the piston.

### PUMP IDENTIFICATION

(Not all model combinations are available  
Consult your Suntec representative)

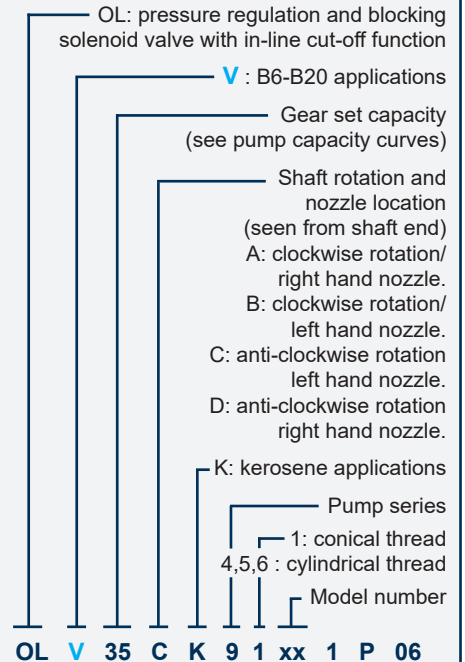

- Revision number \_\_\_\_\_
- Installation \_\_\_\_\_
- P : by-pass plug inserted in return port for two-pipe operation
- M : without by-pass plug, return plugged, for one-pipe operation
- Solenoid valve voltage \_\_\_\_\_
- 02 : 24 V AC
- 06 : 110-120 V AC
- 05 : 220-240 V AC

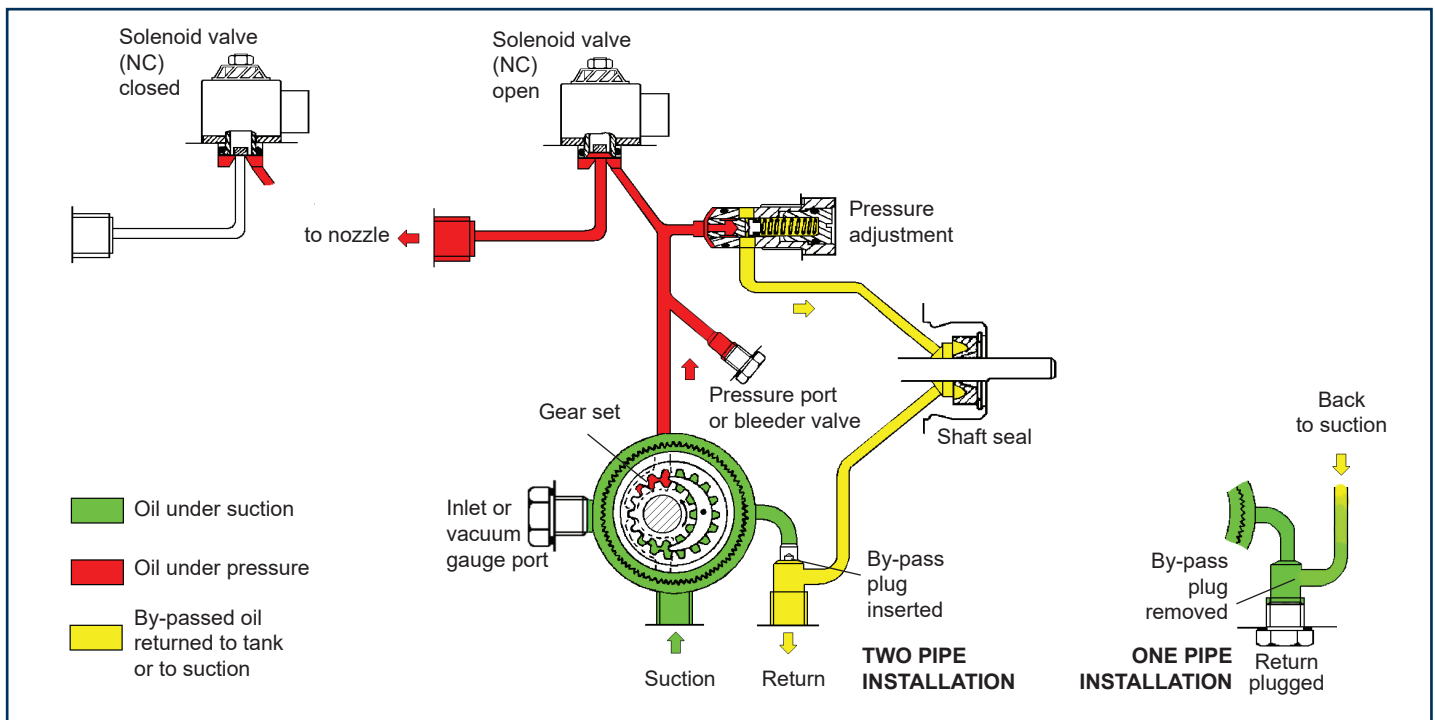

# TECHNICAL DATA

## General

Mounting	Flange mounting <i>Hub mounting available for OL 35/55/65</i>	
Connection threads	Conical :	Cylindrical (according to ISO 228/1) :
Suction and return	1/4 NPTF	G 1/4
Nozzle outlet	1/8 NPTF	G 1/8
Pressure gauge port	1/8 NPTF	G 1/8
Vacuum gauge	1/4 NPTF	G 1/8
Valve function	Pressure regulation	
Strainer	Open area :	0,93 in <sup>2</sup>
	Opening size :	5.90 mil
Shaft	5/16 " dia.	
By-pass plug	Inserted in return port for 2 pipe system; to be removed with a 3/16" Allen key for 1 pipe system.	
Weight	3.44 lbs	

Certification



## Hydraulic data

Gear size	Nozzle pressure range	Factory setting*
35/55	60 - 260 or 120 - 210 psi @5 cSt	200 or 175 psi
65/95	145 - 175 psi @5 cSt	175 psi
35K/55K/65K (Kerosene models)	120 - 210 psi @ 1,8 cSt	175 psi
<i>*other ranges available on request, refer to the specified range of the particular fuel unit.</i>		
Operating viscosity	2 - 12 cSt for OL 35/55/65/95 1.25 - 12 cSt for OL 35K/55K/65K	
Oil temperature	32 - 140°F in the pump	
Ambient temperature	32 - 140°F	
Inlet and return pressures	10 psi max. <i>NFPA limits pressures to 3 psi max</i>	
Suction height	Single pipe : 6" Hg max. vacuum, Two-pipe : 12" Hg max. vacuum, to prevent air separation from oil	
Rated speed	3600 rpm max.	
Torque (@ 45 rpm)	0.88 lb.in (OL 35/35K/55/55K) 1.06 lb.in (OL 65/65K)	

## Solenoid valve characteristics

Frequency	50/60 Hz
Consumption	9 W
Maximum pressure	300 psi

## Pump capacity

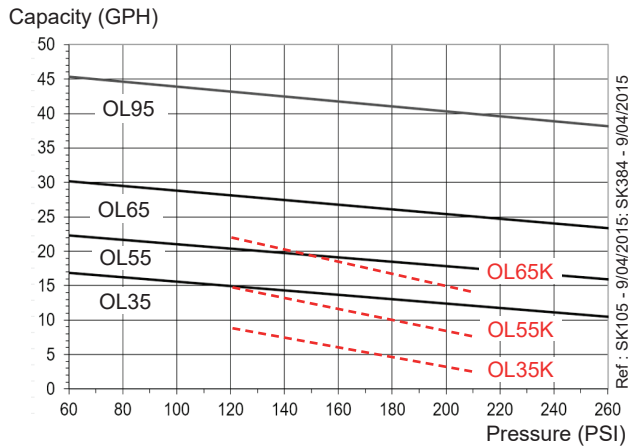

Viscosity = — 5 cSt - Rated speed = 3450 rpm  
- - - 1,8 cSt

Data shown take into account a wear margin.  
Do not oversize the pump when selecting the gear capacity.

## Power consumption

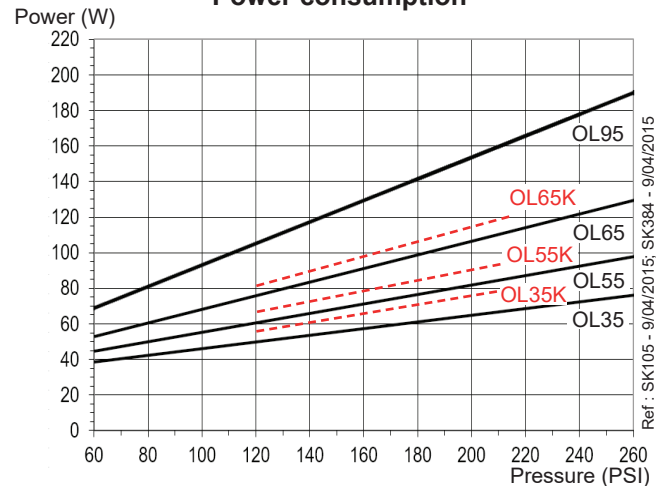

Viscosity = — 5 cSt - Rated speed = 3450 rpm  
- - - 1,8 cSt

## PUMP DIMENSIONS

Example shows "A" rotation and nozzle outlet

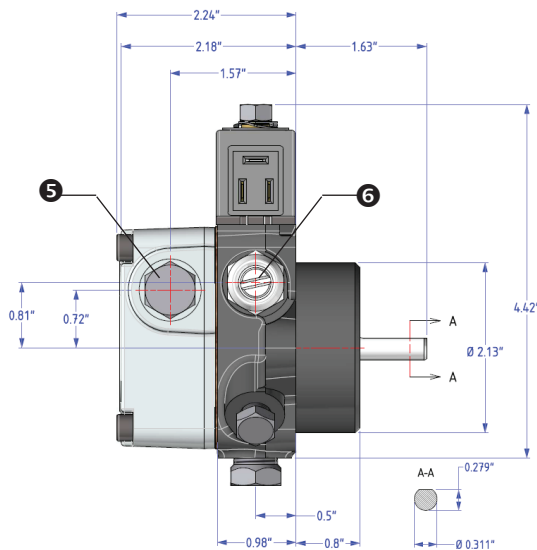

Pump revision 1 - Flange mounting

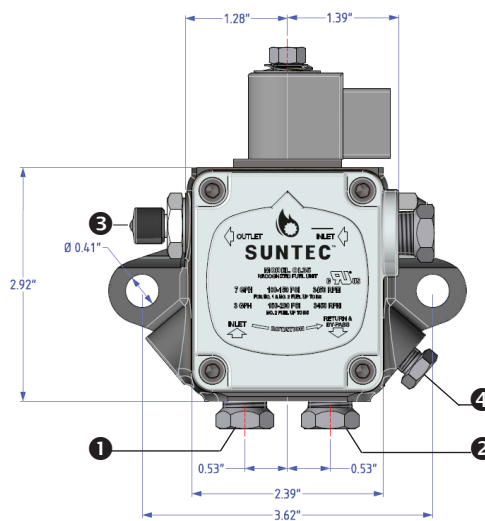

Pump revision 4 - hub mounting

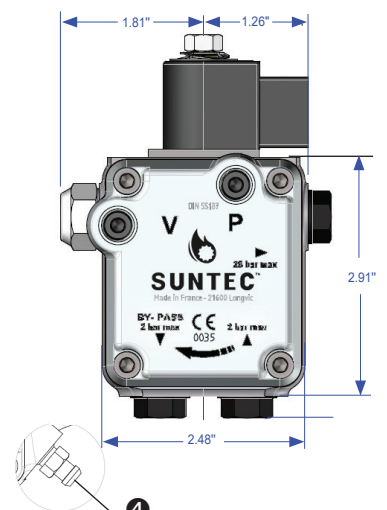

- 1 Suction
- 2 Return and internal by-pass plug
- 3 Nozzle outlet
- 4 Pressure gauge port or bleeder valve
- 5 Inlet or vacuum gauge port
- 6 Pressure adjustment