

SUNTEC B-8000B model contains a unique and hydraulic safety cut-on/off, driven by a motor speed dependent device, and a high single pipe lift capacity. The first stage gear set sucks the fuel from the line, and the second stage gear set pressurizes the fuel. This unit is supplied for 1-pipe operation, without by-pass plug installed. Please verify before installation.

COMPATIBILITY

Fuel oil #2 and lighter, B6-B100 (blends from 6% up to 100% biodiesel, per ASTM D396).

PUMP OPERATING PRINCIPLE

As the motor starts, the fuel from the second stage gearset flowing through the cone valve creates a pressure drop across the diaphragm valve. When the pressure difference is sufficient to overcome the spring force, the diaphragm valve closes and the pressure is built up causing the piston to open and the fuel flow through the nozzle port.

The piston spring is adjusted such that a given nozzle pressure can be maintained while any resulting excess fuel is dumped.

Cut-off speed is factory set so that the cone valve gives the necessary pressure drop to open the diaphragm valve. This in turn reduces the piston chamber pressure and the piston shuts off the nozzle.

One pipe installation :

The by-pass plug must not be installed. The excess fuel is returned back to the inlet.

Two pipe installation :

The steel plug of the return port must be removed and the by-pass plug must be inserted in the return port allowing excess fuel is bypassed back to the tank. The return plug must not be reinstalled.

Bleed :

In one pipe operation, the easy flow bleeder valve must be loosened to bleed the system. Bleeding in two pipe operation is automatic, but it may be accelerated by loosening the easy flow bleeder.

PUMP IDENTIFICATION

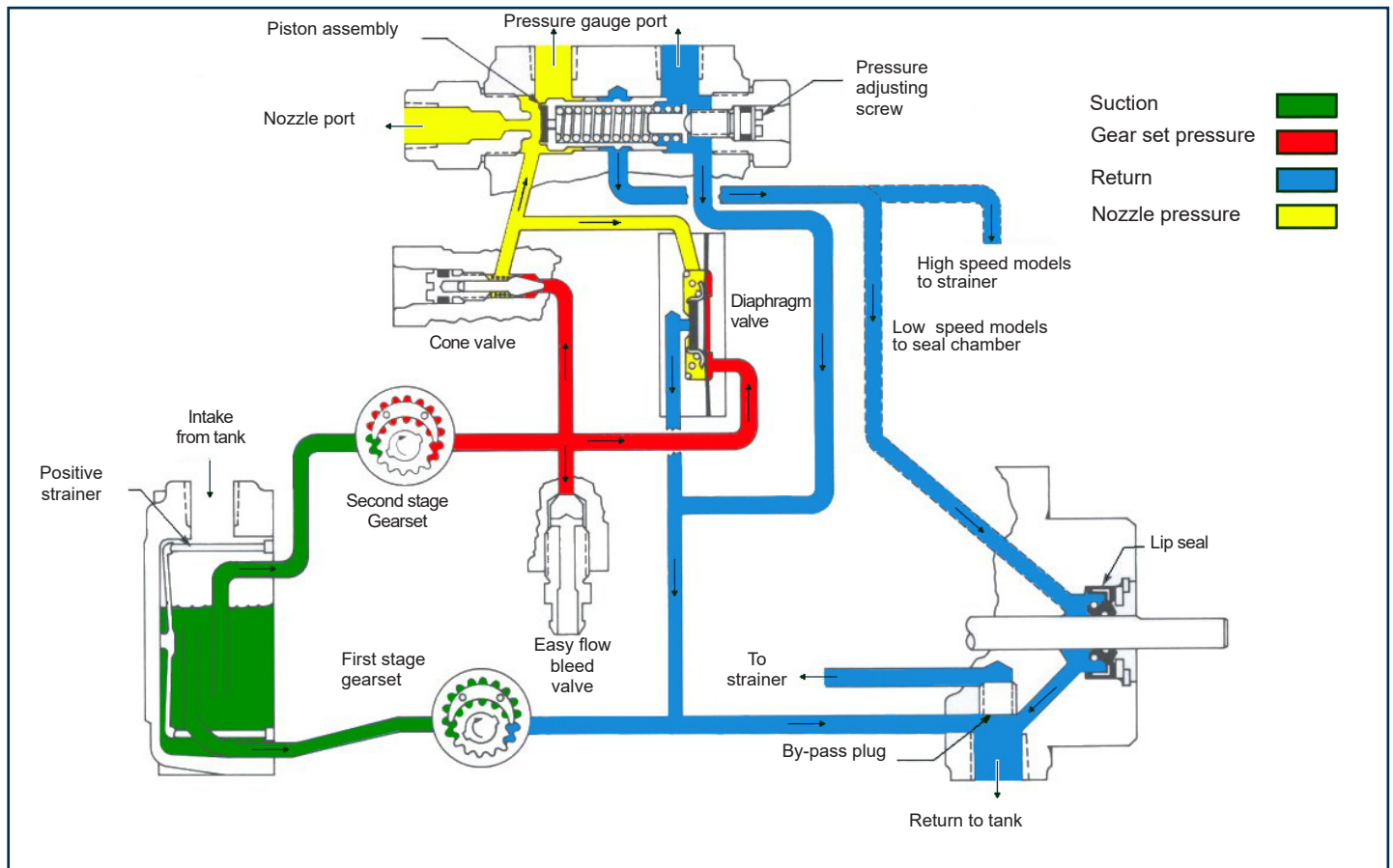
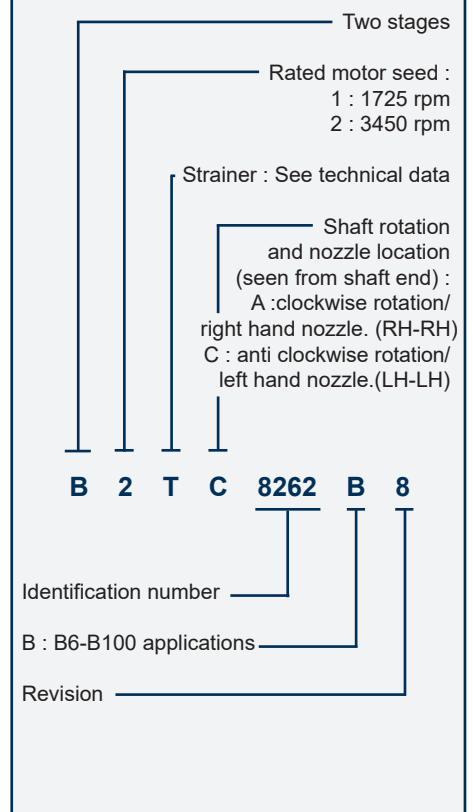

TECHNICAL DATA

General

| | |
|---------------------|---|
| Mounting | Flange mounting |
| Connection threads | |
| Inlet | 1/4 NPTF |
| Nozzle outlet | 1/8 NPTF |
| Pressure gauge port | 1/8 NPTF |
| Bleeder valve port | 1/8 NPTF |
| Valve function | Pressure regulation and cut-off |
| Cut-off | Motor speed dependent |
| Shaft | 5/16 in |
| By-pass plug | Not inserted in return port, for one pipe system. To be inserted in return port with a 5/32 Allen key for two-pipe system |

| | |
|--------------------|--|
| Strainer open area | V = min 3 in ² Y = min 5 in ² T = min 10.5 in ² |
|--------------------|--|

Certified



B6-B100: US only
except B2VA-8241B

Hydraulic data

| | |
|----------------------------|---|
| Oil temperature | 32 - 140°F |
| Ambiant temperature | 32 - 140°F |
| Inlet and return pressures | 10 psi max. <i>NFPA limits pressures to 3 psi max</i> |
| Suction height | Single pipe: 6" Hg max. vacuum, Two-pipe: 17" Hg max. vacuum, to prevent air separation from oil |

Nozzle rating

| Model number | Pressure range | Delivery pressure | Nozzle rating | Power consumption at delivery pressure |
|--------------|----------------|-------------------|---------------------------------------|--|
| B1VA-8212B | 100 to 150 PSI | 100 PSI | 3 GPH at 100 PSI | 80W |
| B2VA-8241B | 10 to 20 PSI | 20 PSI | 20 GPH at 20 PSI | 60W |
| B2TA-8248B | 100 to 150 PSI | 100 PSI | 8 GPH at 150 PSI | 100W |
| B2TA-8260B | 100 to 200 PSI | 100 PSI | 23 GPH at 100 PSI / 15 GPH at 200 PSI | 130W |
| B2TC-8262B | 100 to 200 PSI | 100 PSI | 23 GPH at 100 PSI / 15 GPH at 200 PSI | 130W |
| B2YA-8916B | 100 to 200 PSI | 100 PSI | 7 GPH at 150 PSI / 3 GPH at 200 PSI | 100W |

PUMP DIMENSIONS (in inches)

