

This is a general documentation; for specific applications not covered by this leaflet, please consult us.

The SUNTEC M2C multifunctional gas valve is a 1-stage system.

This multifunctional gas valve consists of 2 safety valves and constant pressure regulator controlled by a servo-regulator.

APPLICATIONS

The SUNTEC multifunctional gas valve is recommended for collective or industrial pressure jet burners.

The use of the SUNTEC multifunctional gas valve is recommended in all gas installations requiring a safety shutoff and pressure control, for inlet pressure up to 360 mbar.

It is suitable for use with 1st, 2nd and 3rd family gases (according to EN 437).

OPERATION PRINCIPLE

Safety valve

M2C multifunctional gas valve comprises two class A automatic safety valves, direct-acting, electrically operated.

At rest, both safety valves are closed; thus gas cannot flow beyond chamber ①.

When energized, the coils open and release the gas flow from chamber ① to chamber ② for safety valve V1 (from chamber ③ to chamber ④ for V2).

When de-energized, each safety valve closes within 0.2 s.

Pressure regulator

The gas pressure regulator is normally closed type, pneumatically operated by a servo system. The servo system controls the main regulator valve opening to equilibrate – through a diaphragm – the downstream pressure (in chamber ③) to a setpoint adjusted by the screw S.

In relation to this given set point, if the gas pressure in the chamber ③ is :

- Lower, the servo-regulator opens and sends pressure into the chamber ⑤ to lift the main diaphragm. The pressure regulator then opens.
 - The regulated pressure (in chamber ③) increases.
- Upper, the servo-regulator closes and sends less pressure into the chamber ⑤ to lower the main diaphragm. The regulator closes partially.
 - The regulated pressure (in chamber ③) decreases.
- Equal to the set pressure, the servo-regulator maintains its opening to maintain the pressure in the chamber ⑤.
 - The regulated pressure (in chamber ③) remains stable.

This design allows for excellent precision when regulating the downstream pressure, regardless to upstream pressure variation or downstream flow changes.

Slow opening (M2C**S)

A hydraulic damper, placed above the safety valve V2, offers the possibility to dampen the movement of the safety valve V2 and thus apply a progressive gas flow in the combustion chamber in the starting phases.

This device allows a fast initial opening (ignition flow) of the safety valve V2, adjustable up to 80% of the maximum flow.

MULTIFUNCTIONAL GAS VALVE IDENTIFICATION

(Not all model combinations are available. Consult your Suntec representative)

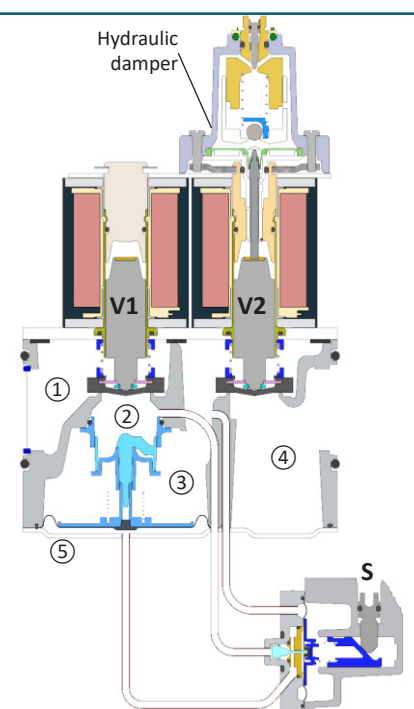
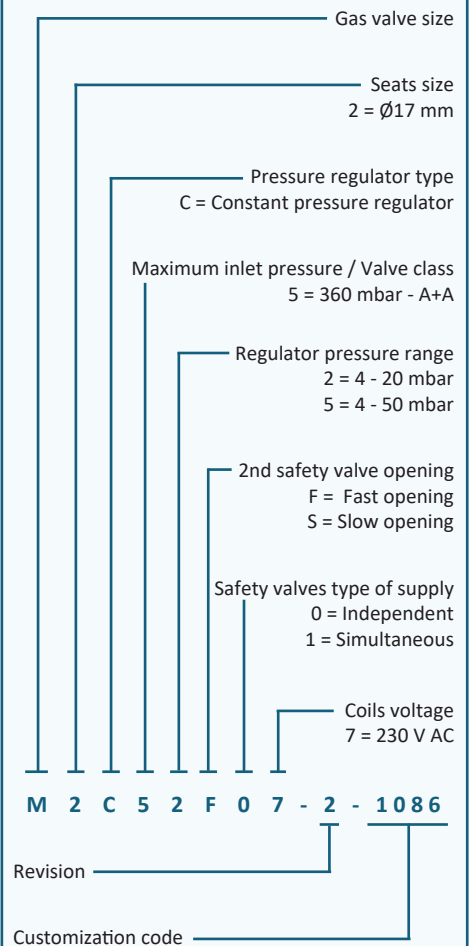

Sectional drawing of multifunctional gas valve
M2C**S

TECHNICAL SPECIFICATIONS

General

Maximum operating pressure	360 mbar
Ambient temperature range	-20°C to +60°C
Operation with	Air and gas of 1st, 2nd and 3rd families
Body	Aluminium
Weight	<ul style="list-style-type: none"> M2C**F : 2.3 kg M2C**S : 2.5 kg
Certification	CE: Certificate n°1312CU6361 UKCA : certificate n°8510/0099
Inlet/outlet flanges	<ul style="list-style-type: none"> DN15 (Rp1/2") DN20 (Rp3/4")
Pressure taps	G1/8" connections Supplied in 3 locations on the multifunctional gas valve, and on inlet/outlet flanges.
Inlet strainer	Mesh size : 0.6 mm. Replaceable filter.
Pressure switch (optional)	Factory mounted on inlet flange. When suitable configuration, can be side-mounted.

Safety valve characteristics

Leakage class	Class A+A
Opening time (EN 161)	<ul style="list-style-type: none"> M2C**F : < 0.5 s M2C**S : < 10 s (For other setting, contact SUNTEC.)
Closing time (EN 161)	<ul style="list-style-type: none"> M2C**F : < 0.2 s M2C**S : < 0.2 s
Voltage	230 V AC, 50/60 Hz
Consumption	34 VA
IP rating	IP54 (with suitable connector) according to EN 60529 standard.

Pressure regulator

Pressure regulator	Class B according to EN 88-1, placed between the safety valves V1 and V2.
Regulated pressure range	<ul style="list-style-type: none"> 4-20 mbar (M2C52**7) 4-50 mbar (M2C55**7)
Delivery pressure	10 mbar

DIMENSIONS

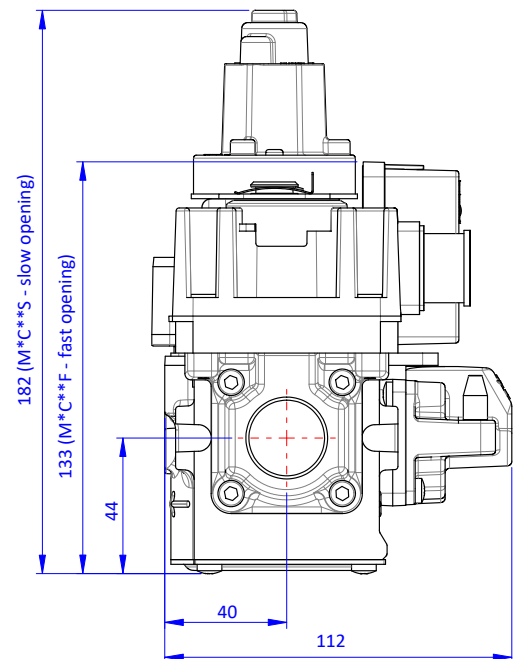
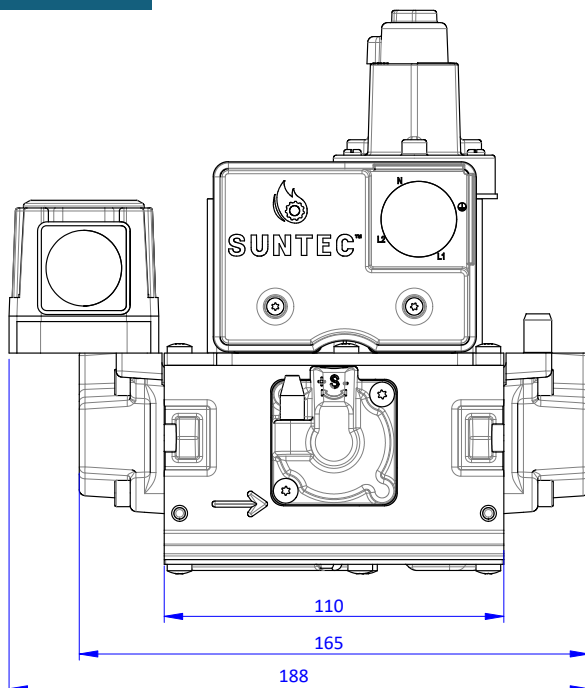

FLOW CURVES

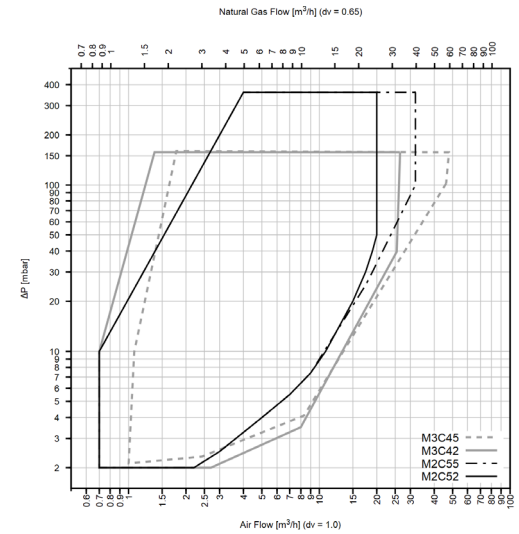

P burner = 3 mbar
Flange = Rp3/4"

Maximum flow can be reduced when other flanges are connected with.