

SUNTEC **B-4000B** model contains a high single pipe lift capacity and a unique hydraulic dual safety cut-on/off driven by :

- A motor speed dependent device
- A solenoid by-passing valve

Cut-on is operated when both mechanisms are released. Cut-off occurs when the speed decrease or the solenoid valve is de-energized.

The first stage gear set sucks the fuel from the line, and the second stage gear set pressurizes the fuel.

This unit is supplied for 1-pipe operation, without by-pass plug installed. Please verify before installation.

COMPATIBILITY

Fuel oil #2 and lighter, B6-B100 (blends from 6% up to 100% biodiesel, per ASTM D396).

PUMP OPERATING PRINCIPLE

As the motor starts, the fuel from the second stage gearset flowing through the cone valve creates a pressure drop across the diaphragm valve. When the pressure difference is sufficient to overcome the spring force, the diaphragm valve closes and the fuel is routed to the piston chamber.

If the solenoid valve (Normally Open) is :

- Opened (de-energized), the fuel flows through the by-pass channel, no pressure will then be built up. The piston will not release the fuel flow through the nozzle.
- Closed (energized) and the diaphragm valve is closed, the pressure is built up causing the piston to open and the fuel flow through the nozzle.

The piston spring is adjusted such that a given nozzle pressure can be maintained while any resulting excess fuel is dumped.

When the solenoid valve is open (de-energized), the valve opens, closing the piston at full operating speed, shutting fuel off the nozzle.

One pipe installation :

The by-pass plug must not be installed. The excess fuel is returned back to the inlet.

Two pipe installation :

The steel plug of the return port must be removed and the by-pass plug must be inserted in the return port allowing excess fuel is bypassed back to the tank. The return plug must not be reinstalled.

Bleed :

In one pipe operation, the easy flow bleeder valve must be loosened to bleed the system. Bleeding in two pipe operation is automatic, but it may be accelerated by loosening the easy flow bleeder.

PUMP IDENTIFICATION

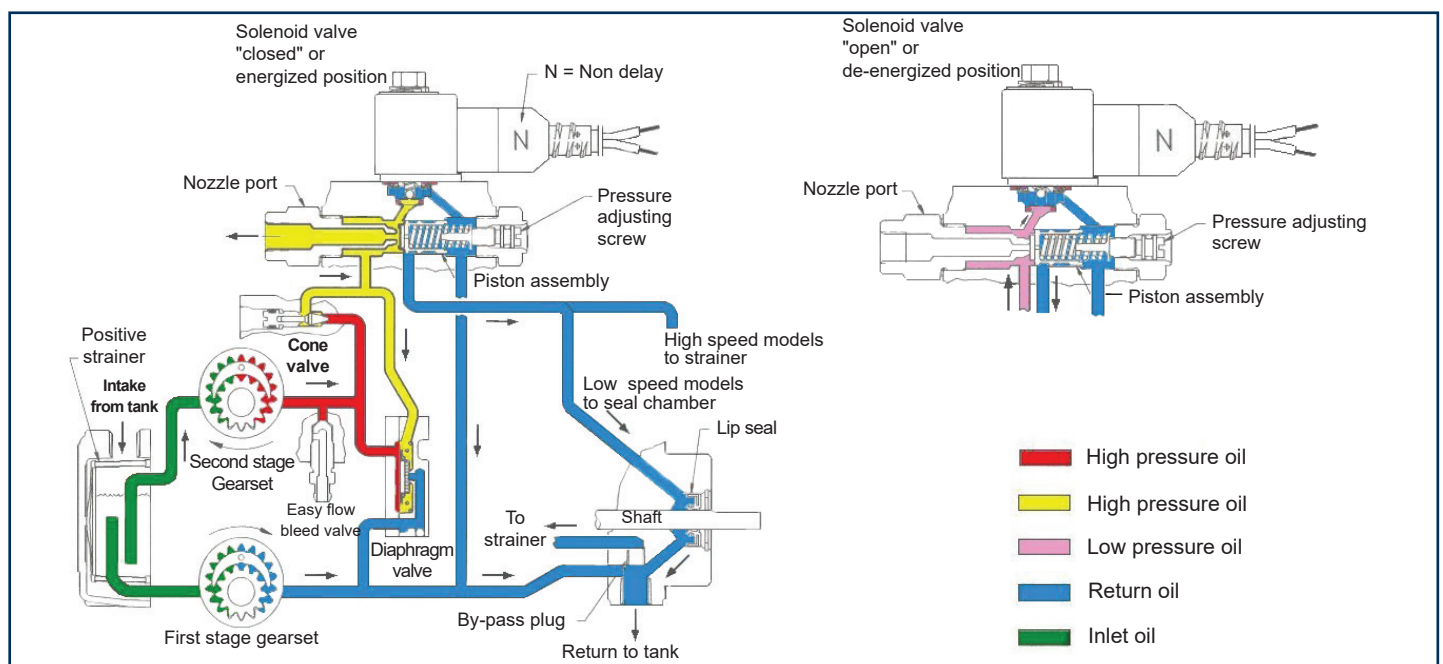
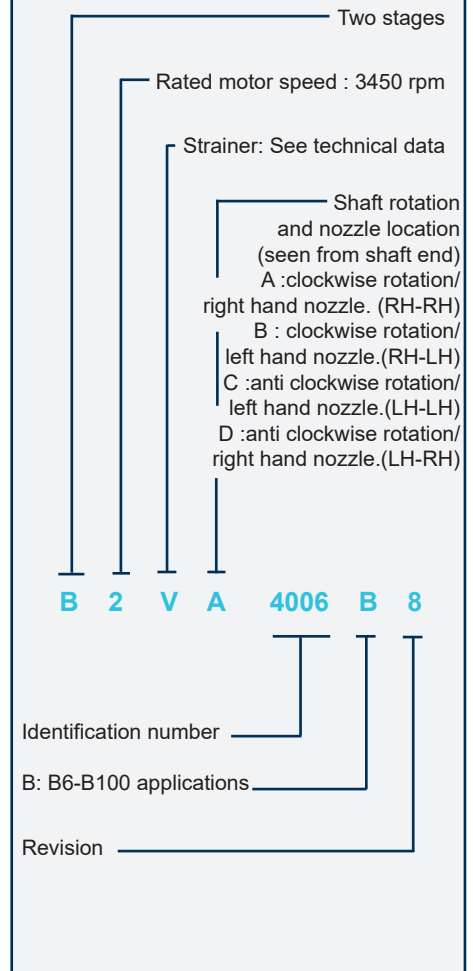

TECHNICAL DATA

General

Mounting	Flange mounting
Connection threads	
Inlet	1/4 NPTF
Nozzle outlet	1/8 NPTF
Pressure gauge port	1/8 NPTF
Bleeder valve port	1/8 NPTF
Valve function	Pressure regulation
Cut-off	Motor speed dependent
Strainer open area	$V = \min 3 \text{ in}^2$
Shaft	5/16 in
By-pass plug	Not inserted in return port, for one pipe system. To be inserted in return port with a 5/32
Certified	 B6-B100: US only

Hydraulic data

Nozzle pressure range	100 - 150 psi (#2 fuel and lighter) 150 - 200 psi (#2 fuel)
Delivery pressure setting	100 psi
Rated nozzle flow	4 GPH @100 - 150 psi (#2 fuel oil and lighter fuel) 3 GPH @150 - 200 psi (#2 fuel oil)
Oil temperature	32 - 140°F
Ambiant temperature	32 - 140°F
Inlet and return pressures	10 psi max. <i>NFPA limits pressures to 3 psi max</i>
Suction height	Single pipe: 6" Hg max. vacuum, Two-pipe: 17" Hg max. vacuum, to prevent air separation from oil
Power consumption	100 W @100 psi

Solenoid valve characteristics

Frequency	50/60 Hz
Consumption	9 W
Maximum pressure	300 psi

Solenoid coil number system

CORDSET TYPE	N 6 2 1 L	R - R.H LEADS
N - NON DELAY		L - L.H LEADS
X - NO CORDSET		(From shaft end)
COIL VOLTAGE		LEADS LENGTHS
2 - 12 VDC/24 VAC		X1 - NO CORDSET
6 - 115 VAC		21 - 13 INCH (PARTIAL JACKET)
7 - 220 VAC		42, 53, 61 - 22.5 INCH (NO JACKET)

PUMP DIMENSIONS

Example shows "A" rotation and nozzle outlet - Dimensions in inch.

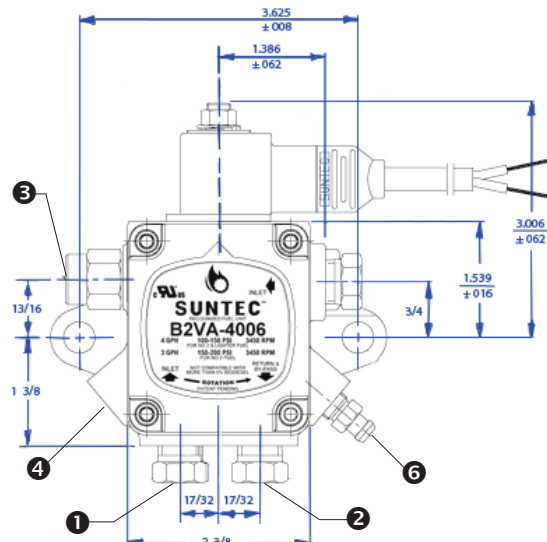
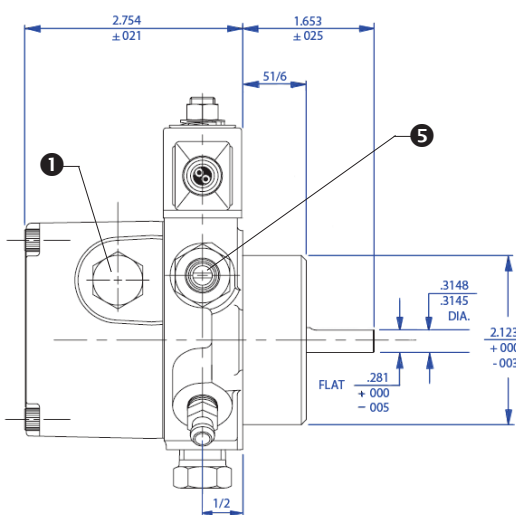

- ① Inlet
- ② Return and internal by-pass plug
- ③ Nozzle outlet
- ④ Cone valve
- ⑤ Pressure adjustment
- ⑥ Bleeder valve