

This is a general specification leaflet ; for specific applications not covered herein, contact Suntec.

The SUNTEC **E 1069** oil pump is specially designed for heavy oil applications: it is fitted with a special type shaft seal resisting high temperature and with a preheater location to render cold starting easier.

APPLICATIONS

- Heavy oil.
- One or two-pipe system.
- Pump associated with in-line solenoid valve to assure cut-off function.

PREHEATING FACILITY

The body of the E 1069 unit includes a drilling to accept an electric preheater. This cavity has been designed to give maximum heat transfer from the heater to the oil in the pump without there being direct contact between the heater cartridge and the oil.

The heating cartridge can be fitted either by right-hand side or by left-hand side. The preheater should be connected for a period of time prior to starting the pump. When the right temperature is reached, it can be switched off or left permanently switched on to maintain fluid oil in the pump during the periodic burner shut-downs. The oil supply, pipes and filters must be separately heated.

PUMP OPERATING PRINCIPLE

The gear set draws oil from the tank through the built-in filter and transfers it to the valve that regulates the oil pressure to the nozzle line. All oil that does not go through the nozzle line will be by-passed through the valve back to the return line in two pipe installation or, if it is a one-pipe installation, back to the suction port in the gear-set. In that case, the by-pass plug must be removed from the return port and the return port sealed by steel plug and washer.

Bleed :

During the starting period, air is purged through the nozzle line : the by-pass hole of the nozzle plug allows air to pass to the nozzle line without opening of the regulator valve.

For the first start up, bleeding can be accelerated by loosening the plug in the pressure gauge port.

Note :

Due to the presence of the by-pass drilling in the nozzle plug, there is no cut-off. Cut-off must be provided by an external solenoid valve.

This drilling prevents high pressure building up in the nozzle line due to expansion of oil from residual heat in nozzle line oil heaters during shut-down periods.

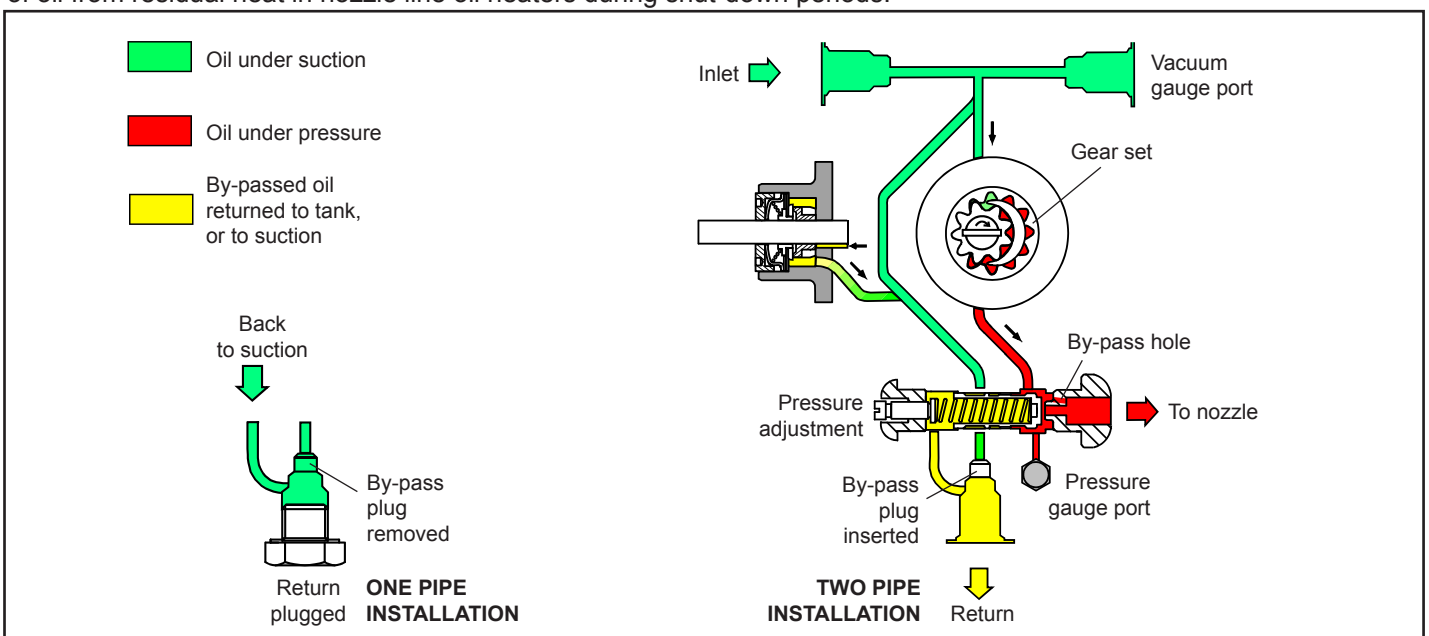
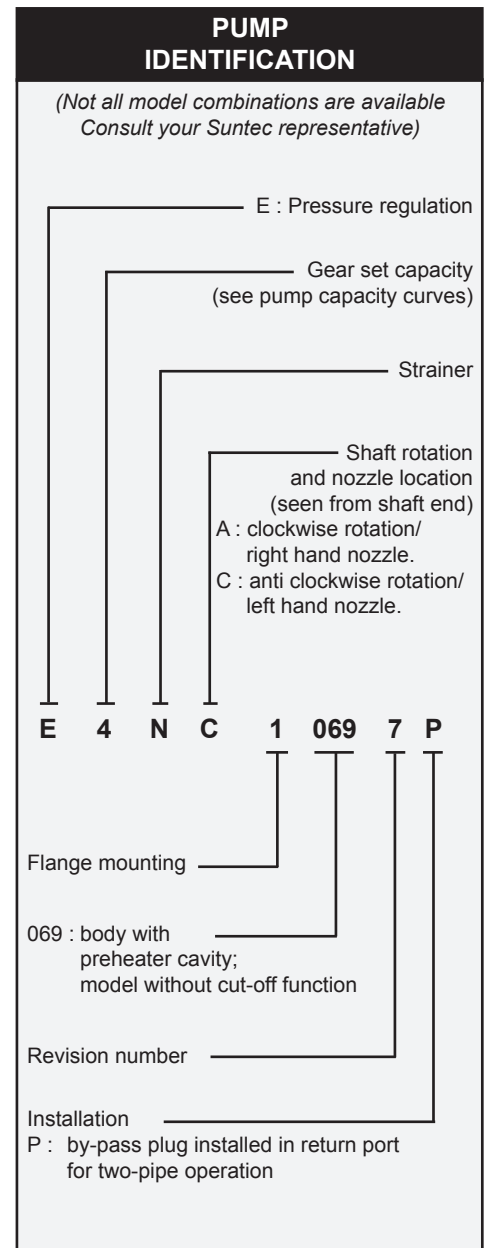

TECHNICAL DATA

General

Mounting	Flange mounting according to EN 225
Connection threads	Cylindrical according to ISO 228/1
Inlet and return	G 1/2
Nozzle outlet	G 1/4
Pressure gauge port	G 1/8
Vacuum gauge port	G 1/2
Valve function	Pressure regulating without cut-off.
Strainer	Open area : 45 cm ² Opening size : 550 μm
Shaft	Ø 11mm according to EN 225
By-pass plug	Inserted in return port for 2 pipe system; to be removed with a 3/16" Allen key for 1 pipe system.
Weight	4 kg

Hydraulic data

Nozzle pressure range	14 - 30 bars
Delivery pressure setting	20 bars
Operating viscosity	3 - 75 mm ² /s (cSt)
<i>(Higher viscosity oil can be used by feeding the pump or by heating the oil to lower its viscosity under 75 cSt)</i>	
Oil temperature	0 - 130°C in the pump.
Inlet pressure	light oil : 0,45 bars max. vacuum to prevent air separation from oil. heavy oil : 3,5 bars max.
Return pressure	light oil : 3,5 bars max. heavy oil : 3,5 bars max.
Rated speed	3600 rpm max.
Torque (@ 40 rpm)	0,30 N.m

Choice of heater

Cartridge	Ø 12 mm
Fitting	according to EN 50262
Rating	50 - 80 W

Pump capacity

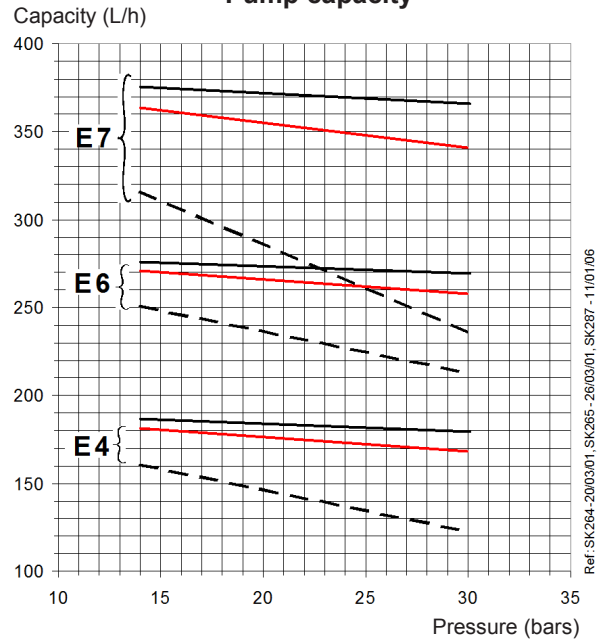

Ref: SK264-2003/01, SK265-26/03/01, SK287-11/01/06

Power consumption

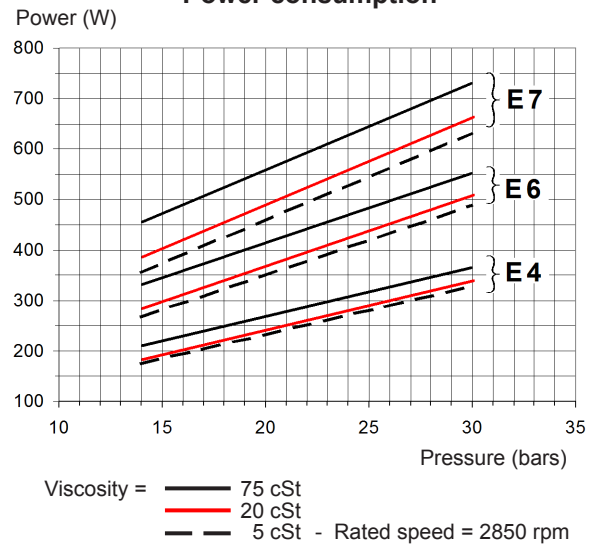

PUMP DIMENSIONS

Example shows "C" rotation and nozzle outlet.

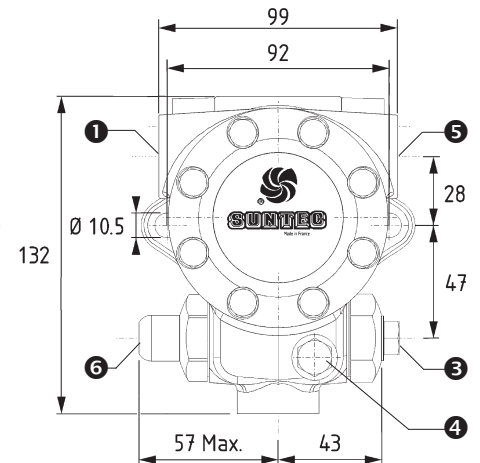
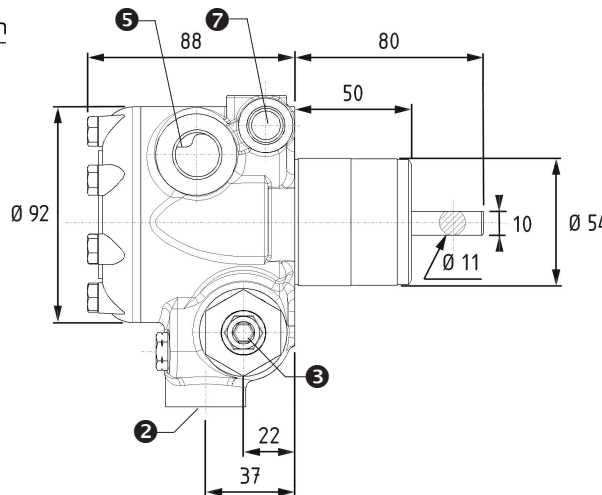
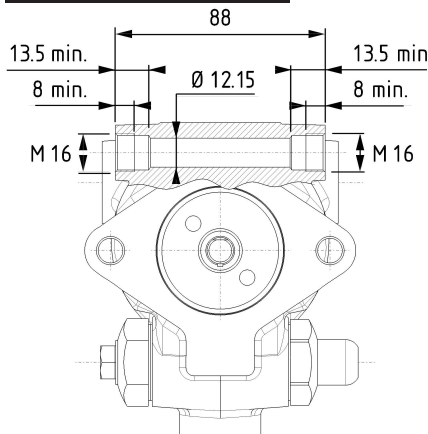

- 1 Suction or vacuum gauge port
- 2 Return and internal by-pass plug
- 3 Nozzle outlet
- 4 Pressure gauge port
- 5 Vacuum gauge port or suction
- 6 Pressure adjustment
- 7 Preheater cavity