

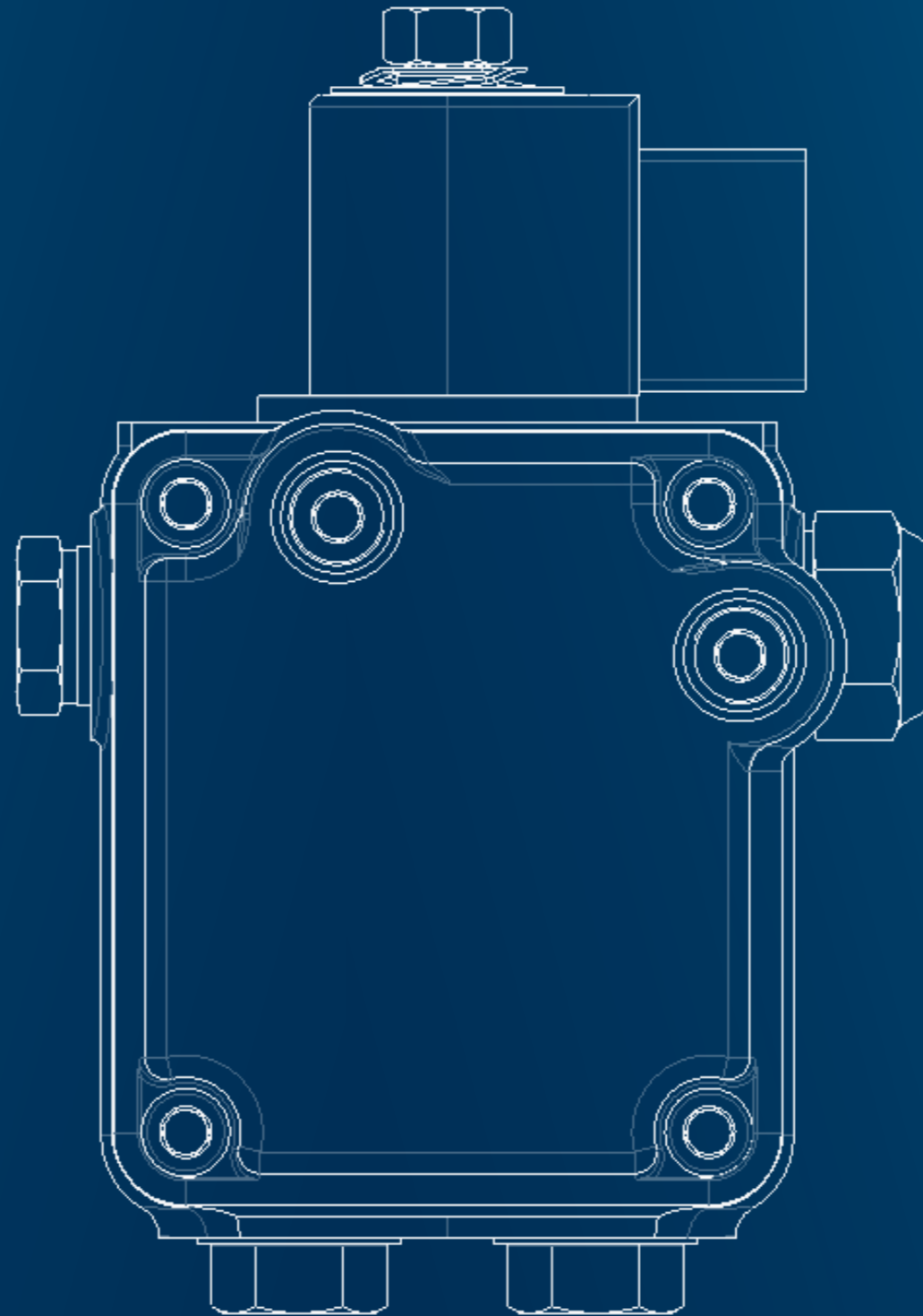

## PUMPS & VALVES

**SUNTEC Industries France**  
1 rue Lavoisier - CS 60102  
F-21603 Longvic Cedex  
☎ : +33 (0)3 80 70 60 70  
☎ : +33 (0)3 80 70 61 11  
✉ : [information@suntec.fr](mailto:information@suntec.fr)  
[www.suntec.fr](http://www.suntec.fr)

**SUNTEC Industries Incorporated**  
60 Aberdeen Drive  
Glasgow, KY 42141  
☎ : +1 270 404 0254  
✉ : [info@suntecpumps.com](mailto:info@suntecpumps.com)  
[www.suntecpumps.com](http://www.suntecpumps.com)



*The heating product you need™*

*More than 80 years of know-how in the heating industry...*

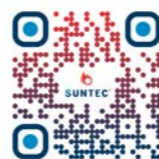

© ALL RIGHTS RESERVED - SUNTEC INDUSTRIES FRANCE SAS - JANUARY 2018



# 600 models of fuel units to choose from

Light oil - Heavy oil - Kerosene - Biofuel

## LOW CAPACITY

Burner capacity from 10 to 1 000 kW

**AE**



Pump with integral pressure regulator.

**AN**



Pump with a combination pressure regulator and piston cut-off valve.

**AL**



Pump with integral blocking solenoid valve with in-line cut-off function (according to DIN EN ISO23553-1). ALE version with nozzle line pressure relief device is specially designed for use with a nozzle incorporating a cut-off function.

**AS**



Pump with integral by-pass solenoid valve which controls the combination pressure regulator and piston cut-off valve (according to DIN EN ISO23553-1).

**AUV**



This pump is specially designed for the after-sales service. It replaces the majority of single step pumps of the market, as well as SUNTEC models AS 47, ASV 47, AL 35, ALV 35, ALE 35 and ALEV 35. This pump is suitable for light oil, Kerosene as well as for B10 applications.

**AP**



Basic model with two adjustable pressure ranges and one nozzle outlet.

**A2L**



Pump with two nozzle outlets and two independent blocking solenoid valves with in-line cut-off function (according to DIN EN ISO23553-1). A single regulator delivers the same pressure for both nozzle lines.

**AT**



Pump with two adjustable pressure ranges, one nozzle outlet and integral in-line solenoid cut-off (according to DIN EN ISO23553-1).

**ATUV**



Pump specially designed for the after-sales service. It replaces the majority of two step pumps of the market, as well as SUNTEC models AT2 45, AT2V 45, ATE2 45, ATE2V 45, AT2 55, AT2V 55, ATE2 55, ATE2V 55.

**AM**



Designed for modulating light-oil burners and condensing boilers, this new pump with its compact design offers a continuous power range, independently of motor speed and oil temperature.

Basic models      Single step models      Two step models      Modulating model

## MEDIUM CAPACITY

Burner capacity from 400 to 3 000 kW

**D**



This small unit can handle medium grade fuel oils. D pump incorporates an adjustable pressure regulator without cut-off.

**AJ**



A compact medium capacity fuel unit for light oil, with adjustable pressure regulator.

**J**



Sought after traditional engineering, this unit for medium capacity light oil burners incorporates a combination pressure regulator and cut-off valve.

**E1001**



Pump with pressure regulator allowing the cut-off, which can be used with kerosene and heavy oil.

**E1069**



Perfect for industrial applications (heavy oil) this pump is designed for a longer life. It can receive a preheater to facilitate cold starting.

## HIGH CAPACITY

Burner capacity from 3 000 to 30 000 kW

**TA**



This high technology fuel unit adapted for the rigours of industrial applications incorporates an integral pressure regulator and a preheater location.

**TAR**



Based on TA range and designed for maritime applications (marine boilers), this pump is suitable for Marine Distillate Fuels and Marine Residual Fuels.

**T**



Same concept as the TA pump, with higher capacity. The pressure regulation is assured by the separate TV Valve.

**TV**



A separate pressure regulator to suit T unit.

## ADDITIONAL PRODUCTS

## GAS VALVES

**SL1**



In-line solenoid valve according to DIN EN ISO23553-1.

**CONNECTORS**



For pumps with solenoid valves. Available in lengths from 35 cm to 1 m.

**FTU**



Pump and motor units for transfer loop or feeding of several burners on the same line.

**SOLENOID PUMPS**



For fuel oil and kerosene applications.

**GAS VALVES**



Combination gas valves (according to EN126:2012) for light commercial gas boilers and pressure jet burners.