

This is a general specification leaflet ; for specific applications not covered herein, contact Suntec.

The SUNTEC J oil pump incorporates a pressure regulating valve with (or without) cut-off function*.

APPLICATIONS

- Light and medium oil.
- One or two-pipe system.
- Normally associated with in-line solenoid valve.

PUMP OPERATING PRINCIPLE

The gear set draws oil from the tank through the built-in filter and transfers it to the valve that regulates the oil pressure to the nozzle line. All oil that does not go through the nozzle line will be dumped through the valve back to the return line in two pipe installation or, if it is a one-pipe installation, back to the suction port in the gear-set. In that case, the by-pass plug must be removed from the return port and the return port sealed by steel plug and washer.

The valve also has a cut-off function* as follows :

During starting period when the gear-set speed is increasing, all the oil passes through a special flat on the piston, back to the return. Once the speed reaches a certain value and the flow can no longer pass through this flat, then the pressure increases rapidly overcoming the valve spring force and opens the valve.

During the stop sequence, the gear-set speed slows down and the valve closes when the gear-set capacity is lower than the flat flow.

The cut-on and cut-off speeds depend on the gear-set size and set pressure.

Bleed :

Bleeding in two pipe operation is automatic, but it may be accelerated by loosening the plug in a pressure gauge port.

In one pipe operation, a pressure port must be opened to bleed the system.

*Owing to the presence of the nozzle by-pass hole, J 1002 and 1003 models have no cut-off function. Cut-off must be provided by an external solenoid valve.

PUMP IDENTIFICATION

(Not all model combinations are available. Consult your Suntec representative)

J : Pressure regulation

Gear set capacity (see pump capacity curves)

Strainer

Shaft rotation and nozzle location (seen from shaft end)

A : clockwise rotation/ right hand nozzle.

B : clockwise rotation/ left hand nozzle.

C : anti clockwise rotation/ left hand nozzle.

D : anti clockwise rotation/ right hand nozzle.

Pressure range

B : 7 - 14 bars

C : 10-21 bars

E : 10-30 bars

J 6 C A C 1 001 5 P

Flange mounting

000 : conical connection threads cut-off function

001 : cylindrical connection threads cut-off function

002 : cylindrical connection threads by-pass nozzle, no cut-off function

003 : conical connection threads by-pass nozzle, no cut-off function

Revision number

5 : for J4 and J6

4 : for J7

Installation

P : by-pass plug installed in return port for two-pipe operation

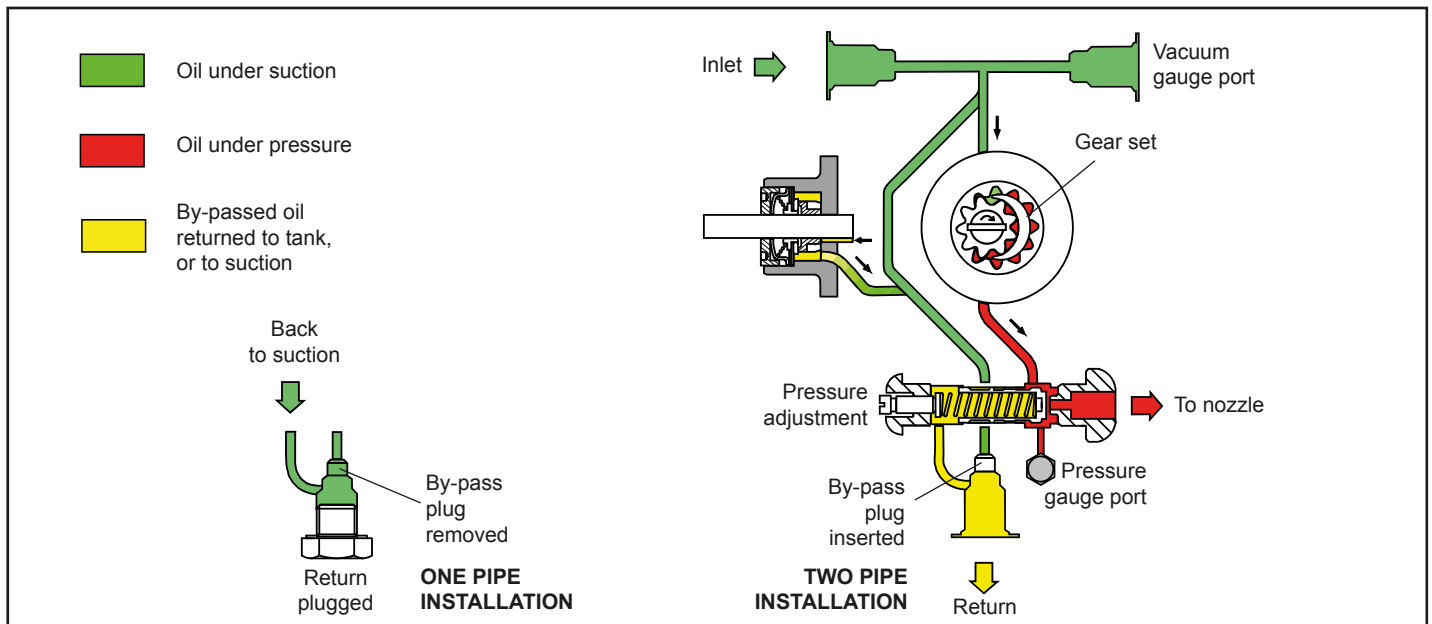

TECHNICAL DATA

General

Mounting	Flange mounting according to EN 225.	
	Models 1000/1003	Models 1001/1002
Connection threads	Conical	Cylindrical (according to ISO 228/1)
Inlet and return	1/4"NPTF	G 1/2
Nozzle outlet	1/8"NPTF	G 1/4
Pressure gauge port	1/8"NPSF	G 1/8
Vacuum gauge port	1/4"NPTF	G 1/2
Valve function	Pressure regulating and cut-off (except for J 1002 and J 1003 models).	
Strainer	Open area : 45 cm ² Opening size : 170 µm	
Shaft	Ø 11mm according to EN 225.	
By-pass plug	Inserted in return port for 2 pipe system; to be removed with a 3/16" Allen key for 1 pipe system.	
Weight	4 kg	

Hydraulic data

Nozzle pressure range	Delivery pressure setting	
B :	7 - 14 bars	7 bars
C :	10 - 21 bars	12 bars
E :	10 - 30 bars	12 bars
Operating viscosity	3 - 75 mm ² /s (cSt)	
Oil temperature	0 - 90°C in the pump.	
Inlet pressure	1,5 bars max.	
Return pressure	1,5 bars max.	
Suction height	0,45 bars max. vacuum to prevent air separation from oil.	
Rated speed	3600 rpm max.	
Torque (@ 45 rpm)	0,30 N.m	

Pump capacity

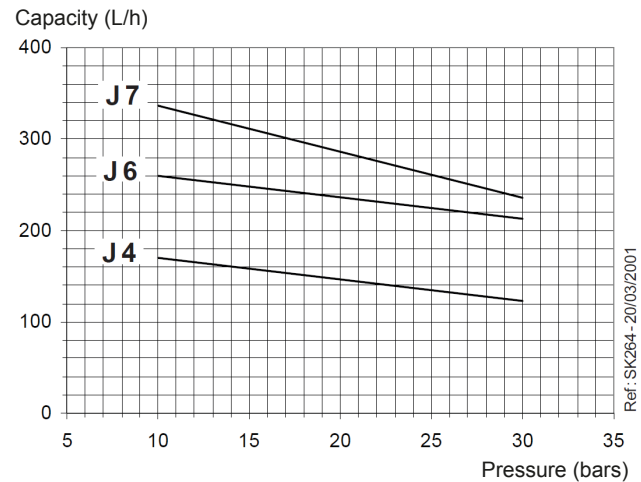

Viscosity = 5 cSt - rated speed = 2850 rpm

Data shown take into account a wear margin.
Do not oversize the pump when selecting the gear capacity.

Power consumption

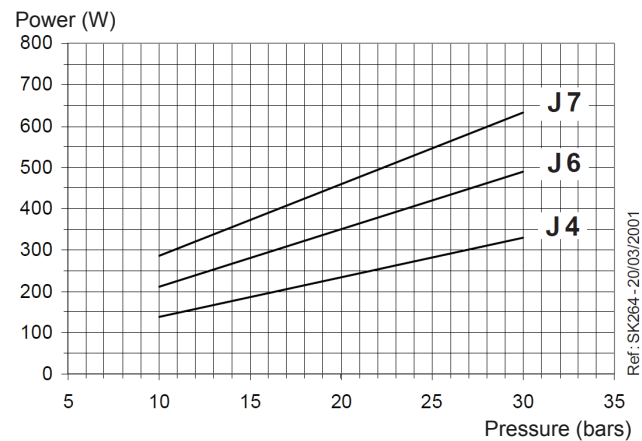

Viscosity = 5 cSt - Rated speed = 2850 rpm

PUMP DIMENSIONS

Example shows "C" rotation and nozzle outlet.

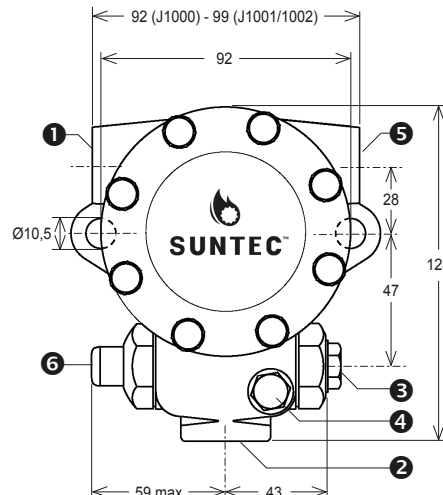
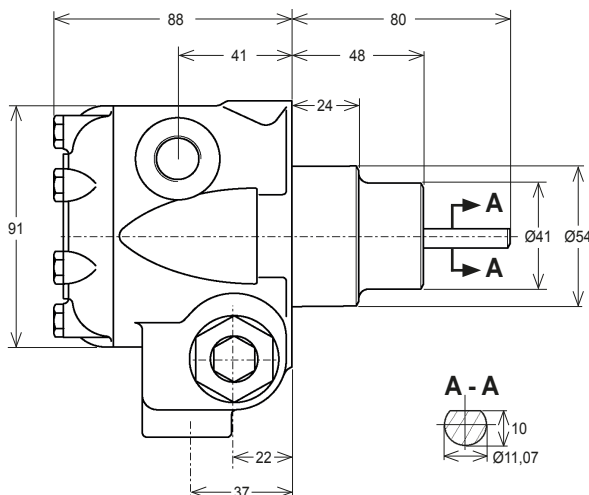

- 1 Suction or vacuum gauge port
- 2 Return and internal by-pass plug
- 3 Nozzle outlet
- 4 Pressure gauge port
- 5 Vacuum gauge port or suction
- 6 Pressure adjustment