

**This document is not contractual; for any specific application, contact SUNTEC.**

The **AM** pump is designed for modulating light-oil burners and condensing boilers.

This new pump with its compact design offers a continuous power range, independently of motor speed and oil temperature.

### APPLICATIONS

- Light oil, B10 heating oil/biofuel blend (as defined in DIN V 51603-6).
- One or two-pipe system.

### PUMP OPERATING PRINCIPLE

The gear set draws oil from the tank through the pump filter and transfers it to an electromagnetic piston pump. The oil which is not used is sent back to the return via a pressure regulator which controls the minimum pressure.

When energized by the coil of the modulating solenoid, the plunger of the piston pump creates a reciprocating movement which increases the pressure of the oil. The output pressure of the oil linearly depends on the supply voltage of the coil.

An integrated pulsation damper stabilizes the outlet pressure.

A pressure sensor port, located after the cut-off solenoid valve, allows the control of the piston pump coil.

### Bleed and suction

Bleeding of the AM pump is automatic in two-pipe operation.

In one-pipe operation, as for a standard gear pump, the plug of a pressure gauge port must be loosened until the air is evacuated from the system.

The suction capacity of the AM pump is identical to a standard SUNTEC gear pump.

### PUMP IDENTIFICATION

(Not all model combinations are available  
Consult your SUNTEC representative)

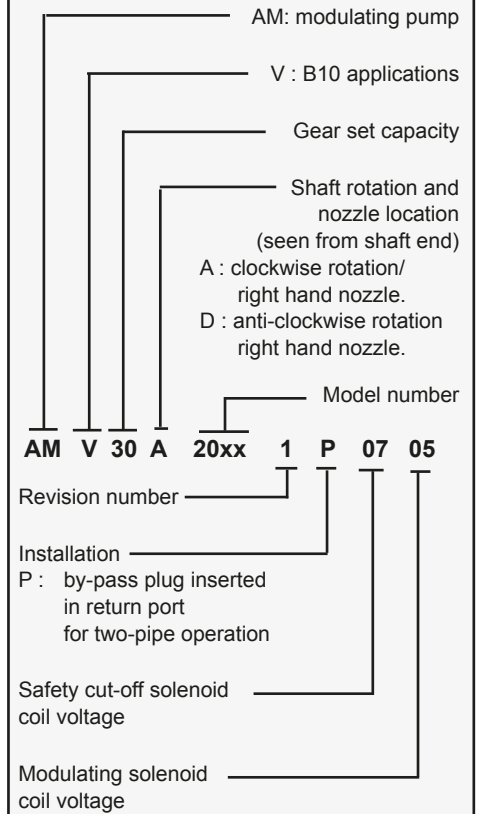

### OPERATING SCHEME

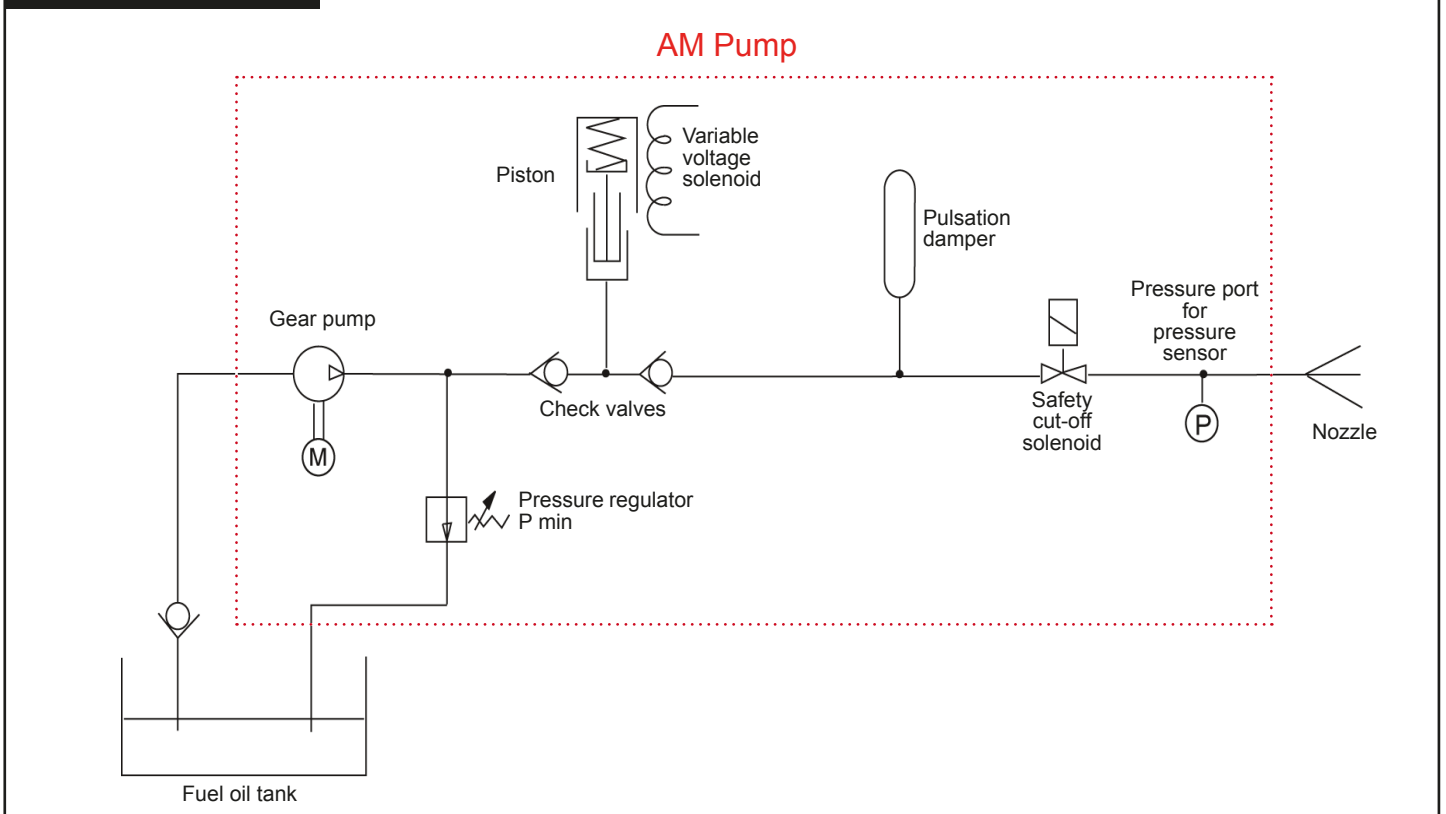

## TECHNICAL DATA

### General

Mounting	Hub mounting according to EN 225.
Connection threads	cylindrical according to ISO 228/1.
Inlet and return	G 1/4 (with facilities for conical sealing)
Nozzle outlet	G 1/8
Pressure gauge port	G 1/8
Vacuum gauge port	G 1/8
Piston valve function	Pressure regulation
Strainer	open area : 6 cm <sup>2</sup> opening size : 150 µm.
Shaft	Ø 8 mm according to EN 225.
By-pass plug	inserted in return port for two-pipe system; to be removed with a 4 mm Allen key for one pipe system.
Ambient temperature	0 - 60°C

### Hydraulic Data

Nozzle pressure range	7 - 25 bars
Operating viscosity	2 - 12 mm <sup>2</sup> /s (cSt)
Oil temperature	0 - 60°C in the pump.
Inlet pressure	2 bars max.
Return pressure	2 bars max.
Suction height	0,45 bars max. vacuum to prevent air separation from oil.
Rated speed	3600 rpm max.
Torque (@ 45 rpm)	0,09 N.m

### Electrical data

<b>Cut-off solenoid</b>	
Voltage	220 - 240 V ; 50/60 Hz <i>(other voltage, please contact SUNTEC)</i>
Power consumption	9 W
Maximum pressure	25 bars
Protection class	IP 54 according to EN 60529, when used with SUNTEC connector cable.

### Modulating solenoid

Voltage	0 - 230 V ; 50 Hz, half wave rectified
Power consumption	10 - 45 VA
Maximum pressure	25 bars
Connection	according to DIN 43650-A
Cable length	80 mm

### Pump pressure vs Nozzle capacity (@ Pmin = 7 bars)

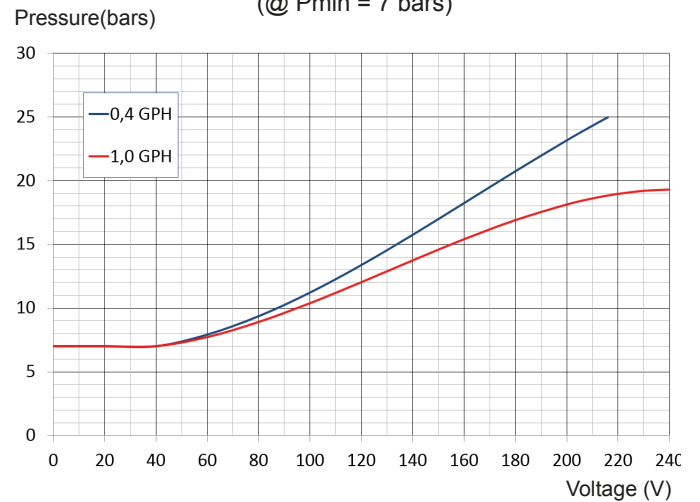

Viscosity = 5 cSt - rated speed = 2850 rpm

### Pump capacity vs Nozzle capacity (@ Pmin = 7 bars)

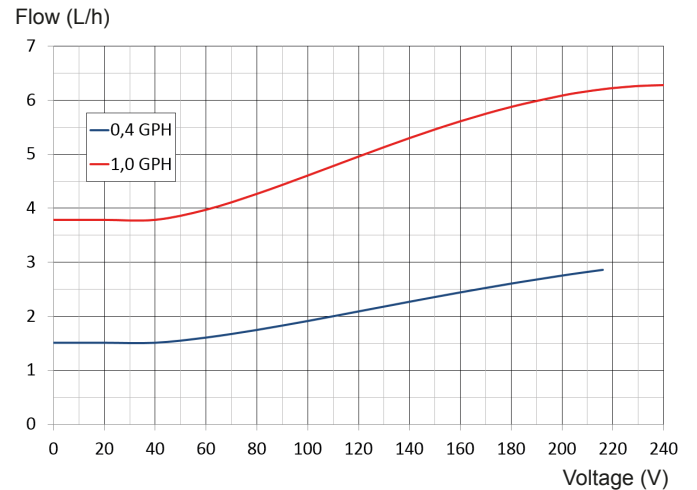

Viscosity = 5 cSt - rated speed = 2850 rpm

## PUMP DIMENSIONS

Example shows "A" rotation and nozzle outlet.

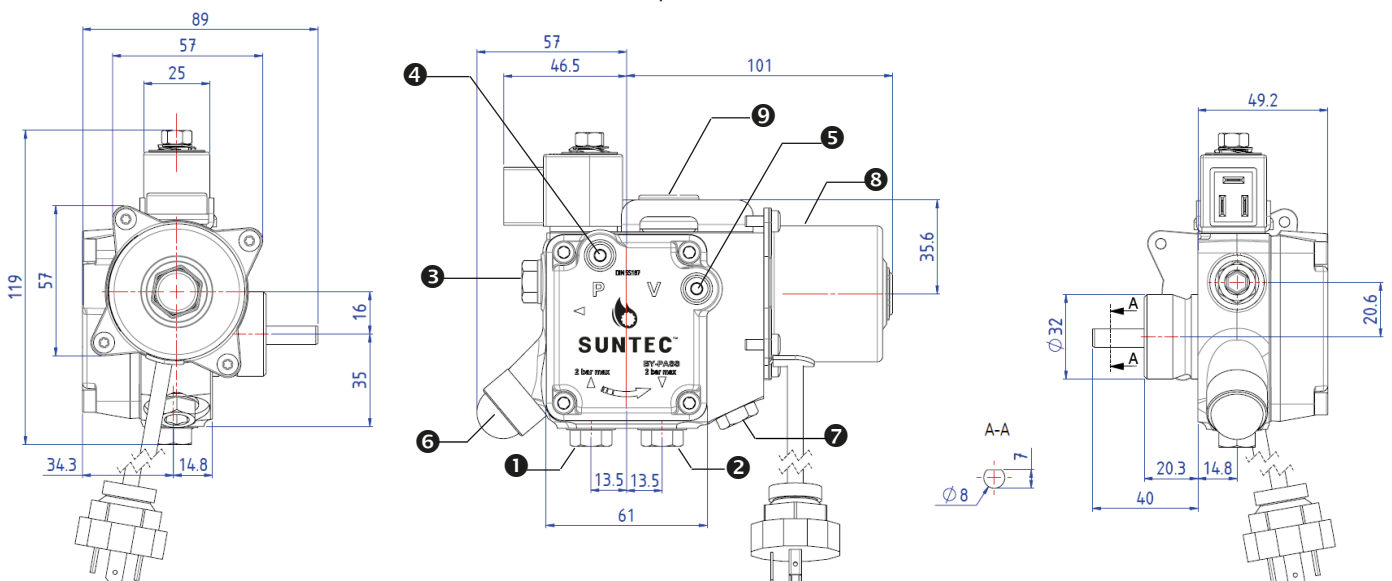

- 1 Suction
- 2 Return and internal by-pass plug
- 3 Nozzle outlet
- 4 Nozzle line pressure gauge port
- 5 Vacuum gauge port
- 6 Pressure adjustment (P min)
- 7 Pressure port
- 8 Variable voltage solenoid
- 9 Pulsation damper