

**This is a general specification leaflet; for specific applications not covered herein, contact Suntec.**

The SUNTEC **AE** oil pump is the basic model incorporating a pressure regulating valve. It does not have a cut-off feature, this allows purging of air through the nozzle line.

## APPLICATIONS

- Light oil, B10 heating oil/biofuel blend (as defined in DIN V51603-6) and kerosene.
- One or two-pipe system.
- System with in-line solenoid valve to assure cut-off function.

## PUMP OPERATING PRINCIPLE

The gear set draws oil from the tank through the built-in filter and transfers it to the valve that regulates the oil pressure to the nozzle line.

All oil which does not go through the nozzle line will be by-passed through the valve back to the return line, in a two pipe installation or, if it is a one-pipe installation, back to the suction port in the gear-set. In that case the by-pass plug must be removed from the return port and the return port sealed by steel plug and washer.

### Bleed :

Bleeding in two pipe operation is automatic.

In one pipe operation, during the starting period, air is purged through the nozzle line : the by-pass hole of the nozzle plug allows air to pass to the nozzle line without opening of the regulator valve.

For the first start up, bleeding can be accelerated by loosening the plug in a pressure gauge port.

### Note :

Owing to the presence of the nozzle by-pass hole, the pump has no cut-off function. Cut-off must be provided by an external solenoid valve (as mentioned in the paragraph APPLICATIONS).

## PUMP IDENTIFICATION

(Not all model combinations are available  
Consult your Suntec representative)

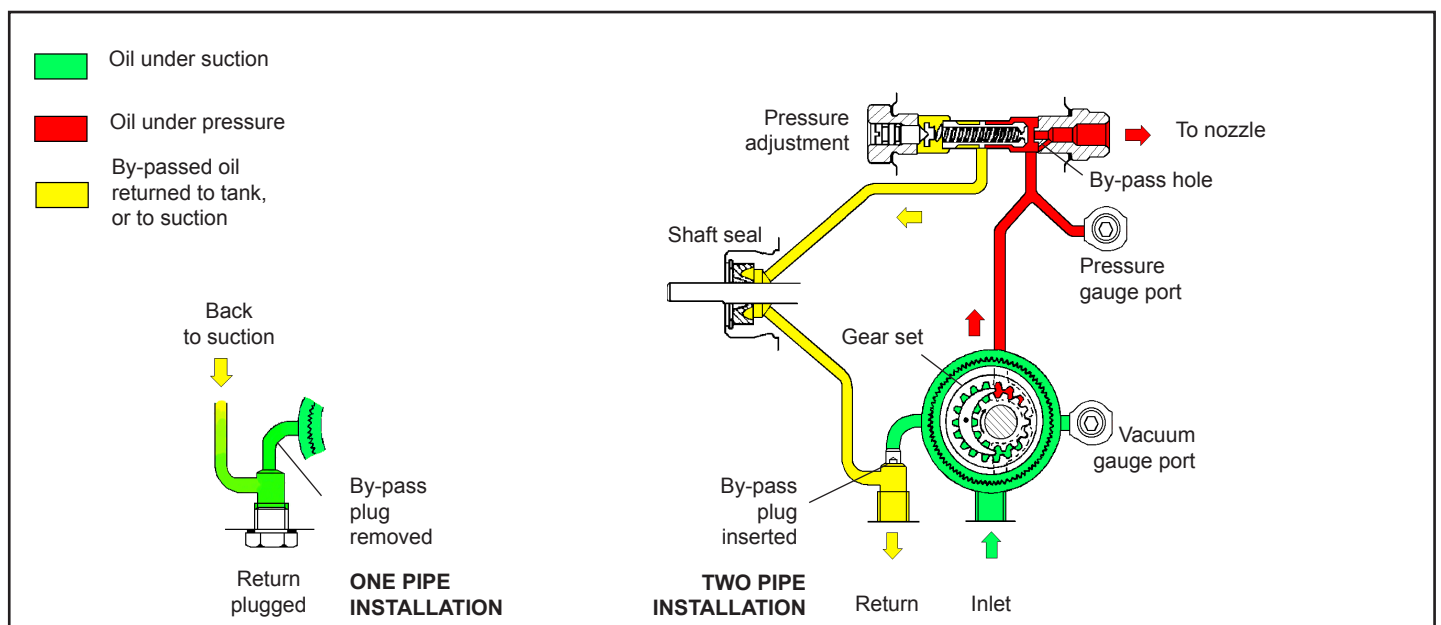
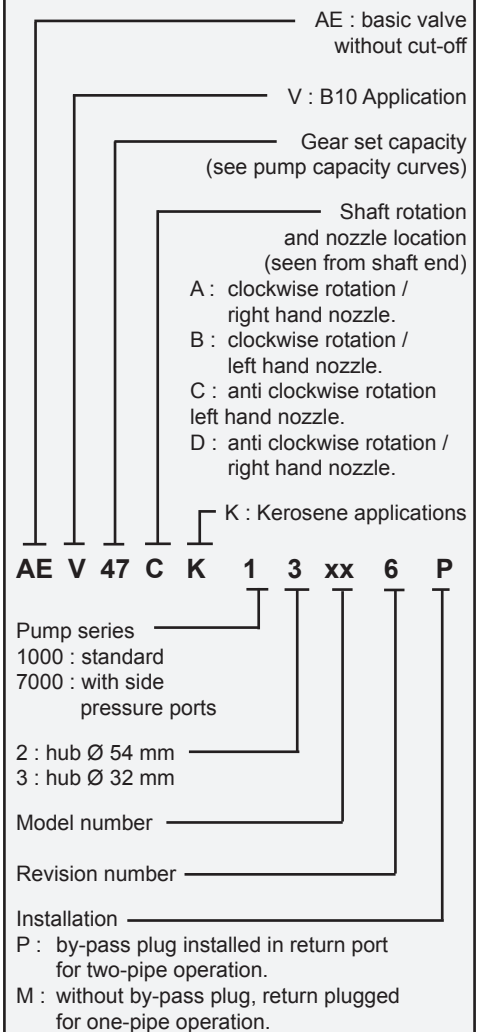

# TECHNICAL DATA

## General

Mounting	Flange or hub according to EN 225
Connection threads	Cylindrical according to ISO 228/1
Inlet and return	G 1/4 (with facilities for conical sealing on revision 6 model)
Nozzle outlet	G 1/8
Pressure gauge ports	G 1/8
Vacuum gauge port	G 1/8
Valve function	Pressure regulating without cut-off
Strainer	Open area : 6 cm <sup>2</sup> (AE 47/47K, 57/57K, 67/67K) 20 cm <sup>2</sup> (AE 77/77K, 97/97K) Opening size : 150 µm
Shaft	Ø 8 mm according to EN 225
By-pass plug	Inserted in return port for two-pipe system; to be removed with a 4 mm Allen key for one-pipe system.
Weight	1 - 1,3 kg (depending on the model)

## Hydraulic data

Gear size	Nozzle pressure range*	Factory setting
47/57	7 - 14 bars	9 bars
67/77/97	8 - 28 bars	14 bars
47K/57K/67K/77K/97K	7 - 15 bars	9 bars

\* other ranges available on request, refer to the specified range of the particular fuel unit.

Operating viscosity	2 - 75 mm <sup>2</sup> /s (cSt) for AE 47/57/67/77/97 1,25 - 75 mm <sup>2</sup> /s (cSt) for AE 47K/57K/67K/77K/97K
Oil temperature	0 - 60°C in the pump.
Inlet pressure	2 bars max.
Return pressure	2 bars max.
Suction height	0,45 bars max. vacuum to prevent air separation from oil.
Rated speed	3600 rpm max.
Torque (@ 45 rpm)	0,10 N.m (AE 47/47K, AE 57/57K) 0,12 N.m (AE 67/67K) 0,14 N.m (AE 77/77K) 0,20 N.m (AE 97/97K)

## Pump capacity

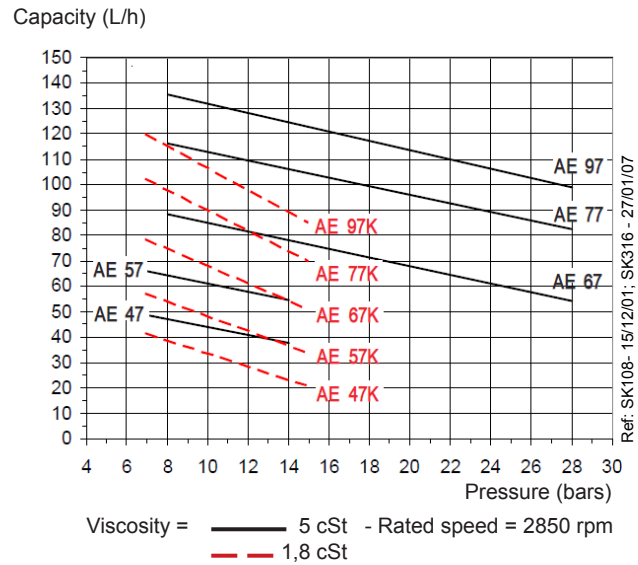

Data shown take into account a wear margin.  
Do not oversize the pump when selecting the gear capacity.

## Power consumption

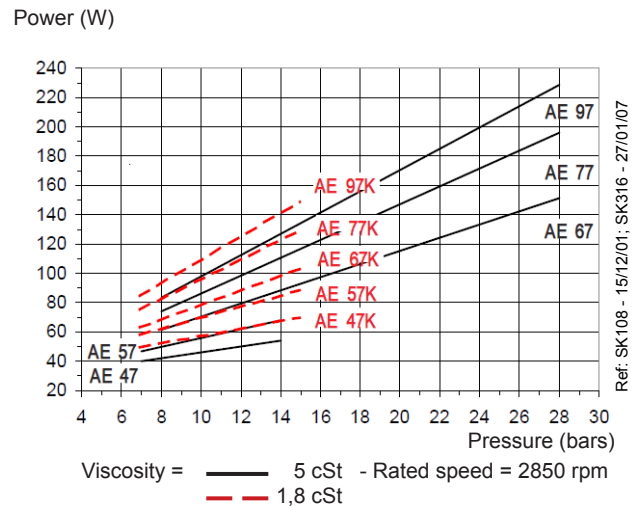

## PUMP DIMENSIONS

Examples show "C" rotation and nozzle outlet.

Pumps revision 6

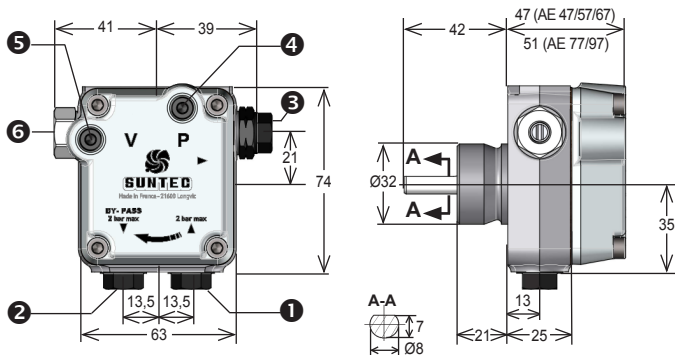

Pumps revision 2

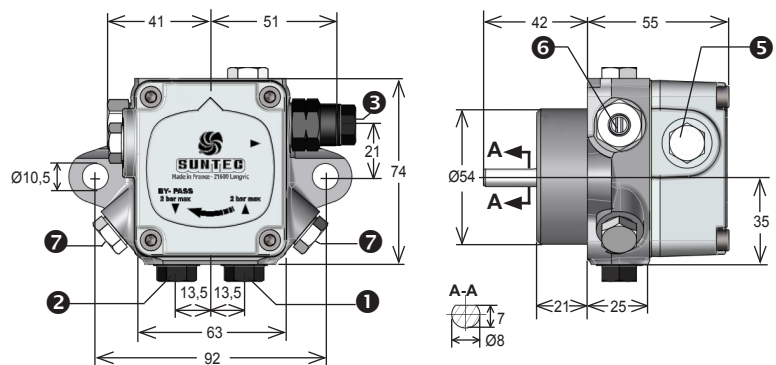

Pumps revision 4

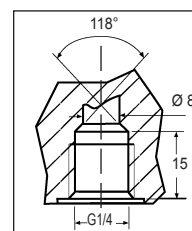
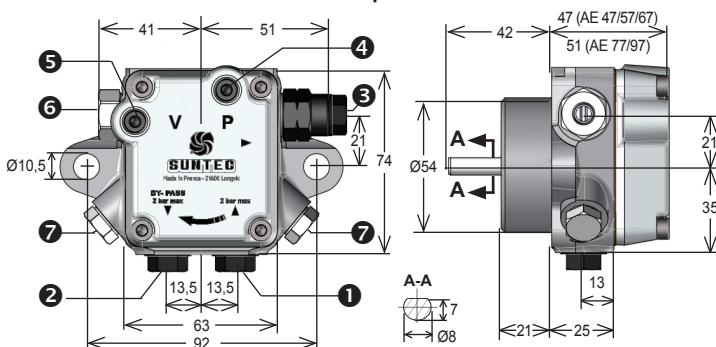

Inlet 1 and Return 2 with direct sealing for revision 6 (sealing with washers can also be used)

- 1 Suction
- 2 Return and internal by-pass plug
- 3 Nozzle outlet
- 4 Pressure gauge port
- 5 Vacuum gauge port
- 6 Pressure adjustment
- 7 Pressure port (only for "7000" series)