

**This is a general specification leaflet ; for specific applications not covered herein, contact Suntec.**

The SUNTEC **A2L** oil pump has two nozzle outlets. It incorporates two blocking solenoid valves with in-line cut-off function, one for each nozzle outlet.

### APPLICATIONS

- Light oil, B10 heating oil/biofuel blend (as defined in DIN V51603-6) and kerosene.
- Two nozzle outlets.
- Two independent blocking solenoid valves.
- A sole regulator for both nozzle lines.

### PUMP OPERATING PRINCIPLE

The gear set draws oil from the tank through the built-in filter and transfers it to the nozzle lines via the cut-off solenoid valves. A pressure regulating valve is used to bypass all oil which is not required at the nozzles.

In two-pipe operation, the by-pass plug must be fitted in the return port, which ensures that the oil bypassed by the regulating valve is returned to the tank and the suction line flow is equal to the gear set capacity.

In one-pipe operation (by-pass plug removed and return plugged), the oil which does not go through the nozzle lines is returned directly to the gear inlet and the suction line flow is equal to the sum of the 2 nozzle flows.

#### Bleed

Bleeding in two-pipe operation is automatic : it is assured by a bleed flat on the piston. In one-pipe operation, the plug of a pressure gauge port must be loosened until the air is evacuated from the system.

#### Cut-off

The solenoid valves of the A2L pump are of the "normally closed" type. Each solenoid valve is situated in one nozzle line. This design ensures extremely fast response and the switching can be selected according to the burner operating sequence and is independent of motor speed.

When the solenoids are non-activated, the valves are closed and all oil pressurized by the gear set passes through the regulator to suction or to the return line, depending upon pipe arrangement.

As soon as the solenoids are activated, oil passes to the nozzle lines at the pressure set by the pressure regulating valve.

The two solenoid valves can be operated independently.

### PUMP IDENTIFICATION

(Not all model combinations are available  
Consult your Suntec representative)

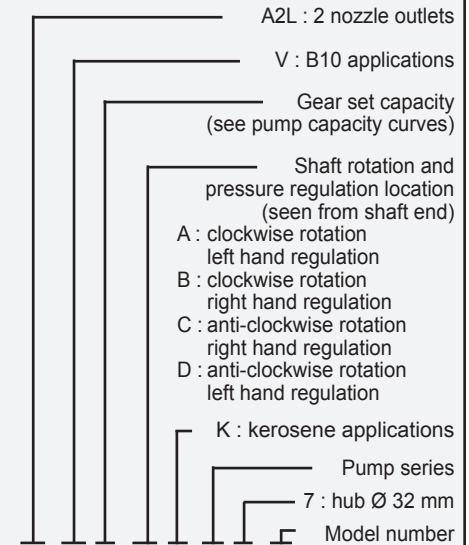

**A2L V 35 C K 9 7 xx 4 P 07 00**

Revision number

Installation

P : by-pass plug inserted for two-pipe operation

M : by-pass plug removed and return plugged for one-pipe operation

Solenoid valve voltage

06 : 110-120 V - 50/60 Hz

02 : 24V - 50/60 Hz

05/07 : 220-240 V - 50/60 Hz

Connector cable length

00 : no cable

35 : 35 cm cable - 45 : 45 cm cable

60 : 60 cm cable - 10 : 1 m cable

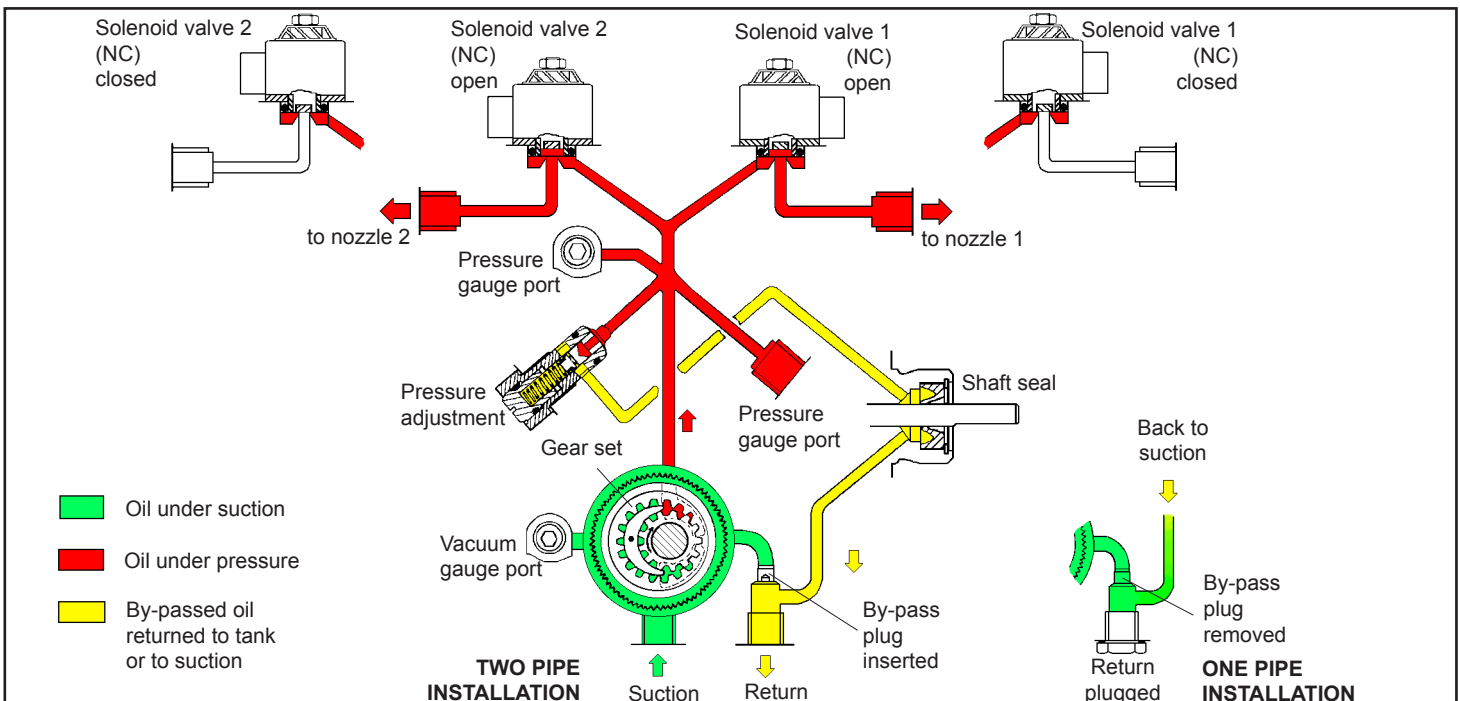

# TECHNICAL DATA

## General

Mounting	Hub mounting according to EN 225
Connection threads	cylindrical according to ISO 228/1
Inlet and return	G 1/4
Nozzle outlet	G 1/8
Pressure gauge port	G 1/8
Vacuum gauge port	G 1/8
Valve function	Pressure regulation
Strainer	Open area : 6 cm <sup>2</sup> (A2L 35/35K/55/55K/65/65K) 20 cm <sup>2</sup> (A2L 75/75K/95/95K) Opening size : 150 µm
Shaft	Ø 8 mm according to EN 225
By-pass plug	inserted in return port for two-pipe system ; to be removed with a 4 mm Allen key for one pipe system.
Weight	1,2 kg

## Hydraulic Data

Nozzle pressure range	8 - 15 bars <i>(other ranges available on request, refer to the specified range of the particular fuel unit)</i>
Delivery pressure setting	9 bars (A2L 35/35K/55/55K/65/65K) 10 bars (A2L 75/75K/95/95K)
Viscosity range	2 - 12 mm <sup>2</sup> /s (cSt) for A2L 35/55/65/75/95 1,25 - 12 mm <sup>2</sup> /s (cSt) for A2L 35K/55K/65K/75K/95K
Oil temperature	0 - 60°C in the pump
Inlet pressure	2 bars max.
Return pressure	2 bars max.
Suction height	0,45 bars max. vacuum to prevent air separation from oil.
Rated speed	3600 rpm max.
Torque (@ 45 rpm)	0,10 N.m (A2L 35/35K/55/55K) - 0,12 N.m (A2L 65/65K) 0,14 N.m (A2L 75/75K) - 0,20 N.m (A2L 95/95K)

## Solenoid valve characteristics

Voltage	220-240 or 110-120 or 24 V; 50/60 Hz
Consumption	9 W max.
Coil Code*	Ambient temperature
06/02/05	0 - 60 °C
07	0 - 80 °C
* Refer to "Pump identification - solenoid coil voltage".	
Maximum pressure	25 bars
Certified	TÜV Nr. stamped on pump cover.
Protection class	IP 54 according to EN 60529, when used with SUNTEC connector cable.

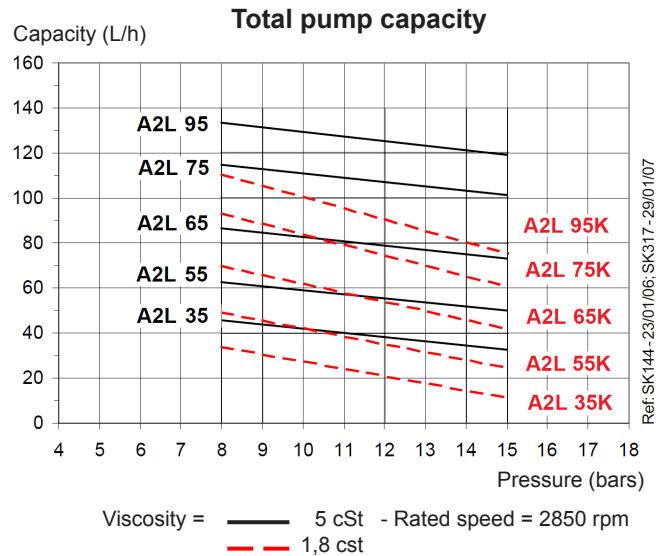

Data shown take into account a wear margin.  
Do not oversize the pump when selecting the gear capacity.

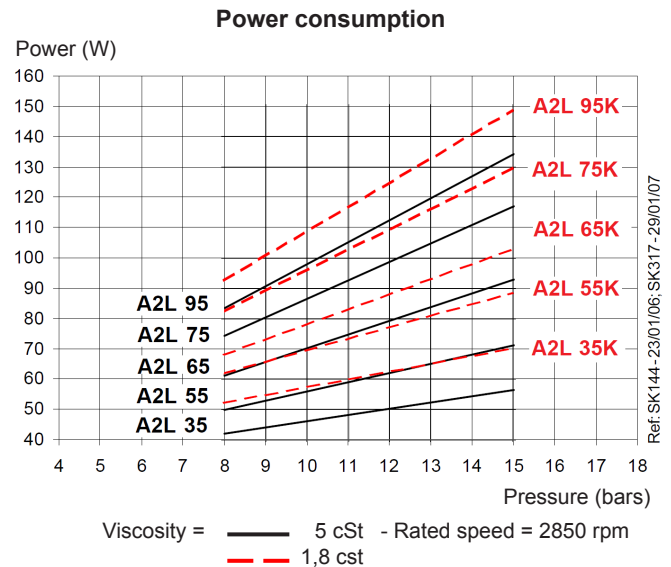

## DIMENSIONS

Examples show "C" configuration.

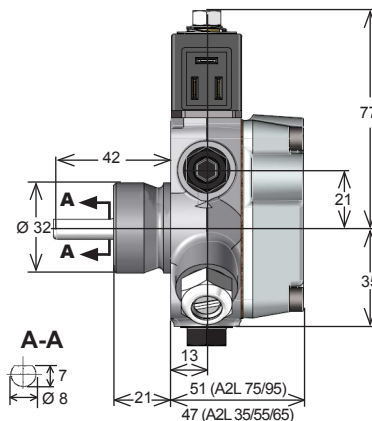
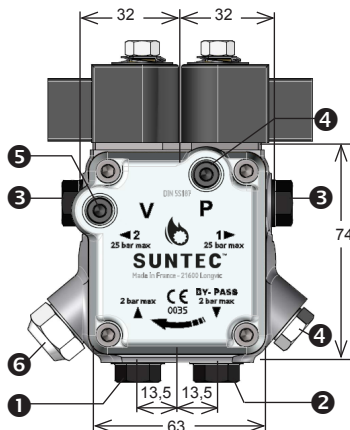

- ① Suction
- ② Return and internal by-pass plug
- ③ Nozzle outlet
- ④ Pressure gauge port
- ⑤ Vacuum gauge port
- ⑥ Pressure adjustment