

BULLETIN N° 90

New design TA and T pumps

Present
design



TA
pump

New
design

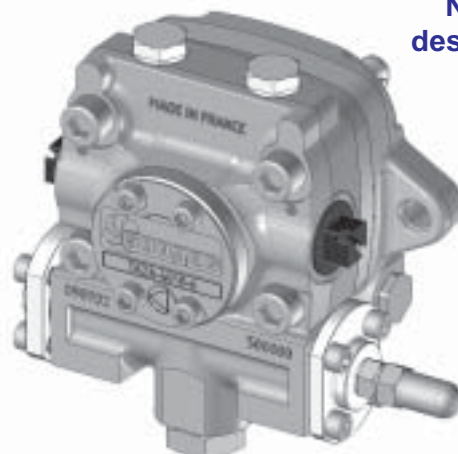

Present
design



T
pump

New
design

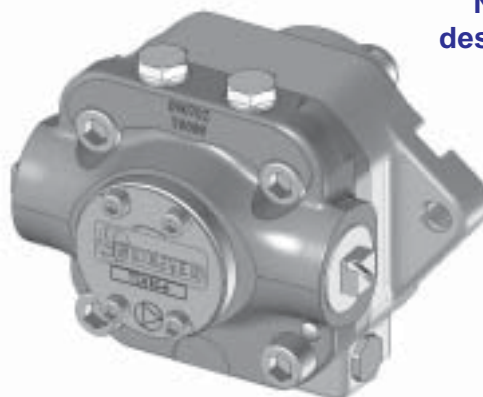

To improve the quality of TA and T pump range, SUNTEC invested in a new 4 axis CNC machining center.

This new production tool will allow us greater flexibility and precision. The manufacturing process will be optimized.

As this new machining center requires new forms of foundry, the external appearance of our TA and T pumps will be slightly modified. The mounting of the pump, the position and dimensions of fittings for inlet and return do not change, the pumps are fully compatible with the existing burners.

To identify this new design, the serial numbers of these pumps will be incremented from 500 000 (for TA pumps) and 50 000 (for T pumps) and the references of these pumps will have a **new revision number : revision 7**.

The designation of these new pumps will be as follows :

TA 3C 4010 **7**, TA4 A 4010 **7**, ... for TA models
T3C 107, T5A 107, ... for T models.

SUNTEC INDUSTRIES FRANCE

1, rue Lavoisier - BP 102 - F-21603 LONGVIC Cedex

Tel. 33 (0)3 80 70 60 70 - Fax 33 (0)3 80 70 61 11 - www.suntec.fr

